



---

## DESIGN EXAMPLE REPORT

<b>Title</b>	<i>Ultra-low Profile (15.4 mm) 65 W Adapter Using TOP259LN</i>
<b>Specification</b>	90 VAC – 265 VAC Input; 19.7 V, 3.33 A Output
<b>Application</b>	Notebook Computer
<b>Author</b>	Applications Engineering Department
<b>Document Number</b>	DER-232
<b>Date</b>	February 9, 2010
<b>Revision</b>	1.0

### Summary and Features

- Low cost, low component count
- Very compact design in a 15.4 mm thin case
- Very low no-load input power (<250 mW at 230 VAC)
- Meets Energy Star 2.0 Efficiency Requirements: >88% at 115 V / 60 Hz, and 230 V / 50 Hz, with very high efficiency in both standby and sleep modes
- Excellent transient load response
- Hysteretic thermal overload protection with automatic recovery
- Latching OVP with fast AC reset
- Meets limited power source requirements (<100 VA) with single point failure
- Power Integrations eSIP low-profile package
- Ultra-low profile transformer bobbin design (PI proprietary SLIMCORE™)
- No potting required to meet thermal specifications
- Meets radiated EMI with > 6dB margin

### PATENT INFORMATION

The products and applications illustrated herein (including transformer construction and circuits external to the products) may be covered by one or more U.S. and foreign patents, or potentially by pending U.S. and foreign patent applications assigned to Power Integrations. A complete list of Power Integrations' patents may be found at [www.powerint.com](http://www.powerint.com). Power Integrations grants its customers a license under certain patent rights as set forth at <http://www.powerint.com/ip.htm>.

## Table of Contents

1	Introduction.....	4
2	Power Supply Specification .....	7
3	Schematic.....	8
4	Bill of Materials .....	9
5	Circuit Description .....	11
5.1	Energy Efficiency.....	11
5.2	Startup and Power Down.....	11
5.2.1	Normal Input Voltage Range .....	11
5.2.2	AC Loss (Power Down) .....	11
5.3	Fast AC reset .....	11
5.4	Output Overload Shutdown .....	12
5.5	Output Over-voltage Protection and Fast AC Reset.....	12
5.6	Thermal Overload Protection.....	12
6	PCB Layout .....	13
7	Transformer Specifications .....	15
7.1	Electrical Diagram .....	15
7.2	Electrical Specifications.....	15
7.3	Materials.....	15
7.4	Transformer Build Diagram .....	16
7.5	Transformer Construction.....	17
7.6	Completed Transformer.....	18
7.7	Transformer Winding Illustrations.....	19
7.8	Common-mode Choke Specifications (L1).....	25
7.9	Electrical Specifications.....	25
7.10	Materials.....	25
7.11	Winding Instructions .....	25
7.12	Illustrations .....	25
7.13	Common-mode Choke Specifications (L2).....	26
7.14	Electrical Specifications.....	26
7.15	Materials.....	26
7.16	Winding Instructions .....	26
7.17	Illustrations .....	26
8	Transformer Design Spreadsheet.....	27
9	Mechanical Drawings .....	31
9.1	Heat Spreader - Main .....	31
9.2	Heat Spreader - Auxillary .....	32
9.3	Output Rectifier Heatsink.....	33
9.4	Bridge Rectifier Heatsink.....	34
9.5	TOP259LN Heatsink .....	35
9.6	Insulator.....	37
10	Assembly of Unit .....	38
11	Power Supply Performance .....	41
11.1	Full Load Efficiency .....	41
11.2	No-load Input Power.....	42



11.3	Active Mode CEC Measurement Data .....	43
11.3.1	Active Mode Efficiency .....	44
11.4	Available Standby Output Power .....	46
11.5	Line and Load Regulation .....	47
12	Thermal Performance .....	49
12.1	Chamber Temperature Data .....	50
12.2	Case Surface Temperature (IR Thermal Image) .....	51
11.2	Case Surface Temperature (Thermocouple Wire) .....	52
13	Waveforms .....	53
13.1.1	Drain Voltage and Current .....	53
13.2	Output Voltage Start-up Profile .....	54
13.3	Hold-up Time .....	55
14	Load Transient Response .....	56
15	Output Rise Time Profile <20 ms .....	57
16	Over Voltage Protection – Latching .....	58
16.1	Overload Protection .....	58
17	AC Reset .....	59
18	Brownout and Recovery .....	60
19	Line Cycle Dropout .....	61
20	Line Sag .....	62
21	Line Swell .....	63
22	Output Ripple Measurements .....	64
22.1.1	Ripple Measurement Technique .....	64
22.1.2	Measurement Results .....	65
23	Control Loop Measurements .....	66
24	Conducted EMI .....	68
25	Revision History .....	74

**Important Note:**

Although this board is designed to satisfy safety isolation requirements, the engineering prototype has not been agency approved. Therefore, all testing should be performed using an isolation transformer to provide the AC input to the prototype board.



## 1 Introduction

This engineering report describes a notebook adapter power supply demonstration board employing the TOPSwitch-HX TOP259LN. This power supply operates from a universal input and provides a 19.7 V, continuous 65 W output.

TOPSwitch-HX maintains constant efficiency across a very wide load range without needing special operating modes for specific load thresholds. This optimizes performance for existing and emerging energy efficiency regulations, such as 1 W standby, 1.7 W and 2.4 W sleep modes, and the Energy Star 2.0 >87% average-efficiency requirements. The constant efficiency delivered by the TOPSwitch products to meet the average-efficiency requirements ensures design optimization for future energy efficiency regulation changes without redesign.

This power supply offers these various protection features:

- Overvoltage protection (OVP) with latching shutdown and fast AC reset
- Primary-side sensed output overload protection, even with a single fault
- Latching open-loop protection with fast AC reset
- Auto-restart overload protection with fast AC reset
- Auto-restart during brownout or line sags
- Accurate thermal overload protection with auto-recovery using a large hysteresis

This document provides complete design information including the specifications, the schematic, and bill of materials for this power supply design. Performance results including regulation, efficiency, standby, transient load, power-limit data, and conducted EMI test results are provided as well.



**Figure 1** – Top View: 65 W Adapter Power Supply in Plastic Case (60 mm x 119 mm x 15.4 mm).



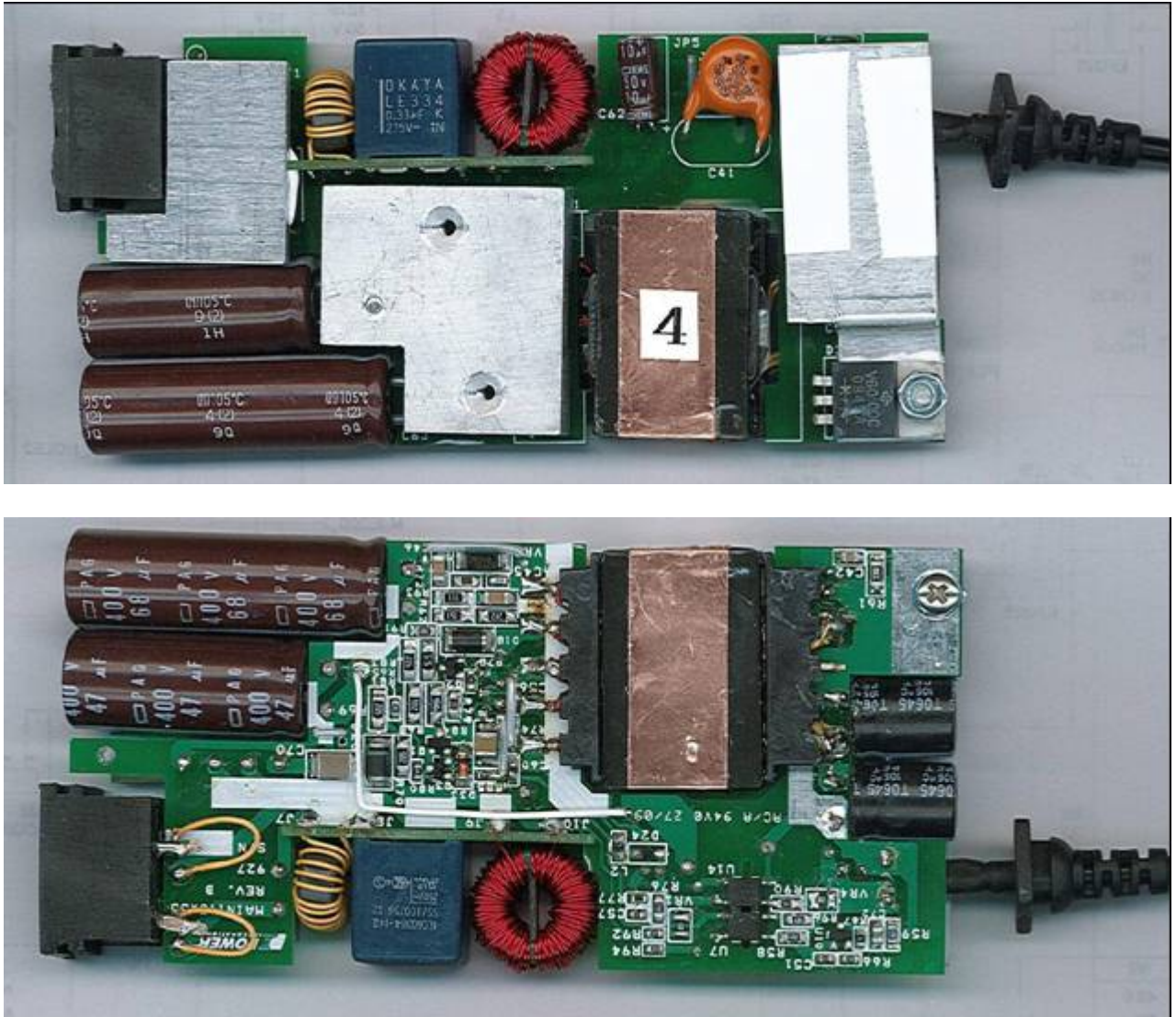


Figure 2 – Top and Bottom View: 65 W Adapter Power Supply.



**Figure 3** – Photograph of Assembled Unit with Heat Spreader in Place.



## 2 Power Supply Specification

The table below represents the minimum acceptable performance of the design. Actual performance is listed in the results section.

Description	Min.	Typ.	Max.	Unit	Notes
<b>Input</b>					
Voltage	90	115/230	265	VAC	2 Wire Input
Frequency	47	50/60	63	Hz	
<b>Output</b>					
Output Voltage 1	18.5	19.5	20.5	V	
Output Ripple Voltage 1			350	mV	20 MHz bandwidth
Output Current 1	0	3.33		A	
Total Output Power		65		W	
<b>Efficiency</b>					
No-Load Input Power			300	mW	
Full Load Efficiency	85			%	65 W, 115/230 VAC
Average Efficiency	87			%	115/230 V; ES 2.0
<b>Available Standby Output Power</b>					
$P_{IN} = 1 \text{ W at } 230 \text{ VAC}$	0.72			W	
$P_{IN} = 1.5 \text{ W at } 230 \text{ VAC}$	1.12			W	
$P_{IN} = 2.4 \text{ W at } 230 \text{ VAC}$	1.97			W	
Standby Efficiency	83%			%	10% output load
<b>Environmental</b>					
Conducted EMI	Designed to meet EN55022B				RTN connected to PE
Safety	Designed to meet IEC950, Class II				
Surge Differential	1			kV	IEC 61000-4-5, 2/12 $\Omega$ generator impedance
Surge Common Mode	2			kV	
ESD Air Discharge			$\pm 15$	kV	
ESD Contact Discharge			$\pm 8$	kV	
Ambient Temperature	0		40	$^{\circ}\text{C}$	Power supply ambient
<b>Miscellaneous</b>					
Startup Time			3	s	AC applied to outputs in regulation
Output Rise Time			50	ms	10% to 90% of steady state output
Holdup Time	10			ms	65 W, 90 VAC
AC Reset Time After Latching Shutdown			2	s	AC input is disconnected and reconnected
Overload Latching Shutdown Time	120			ms	>3.5 A load on 24 V output
Over voltage protection			24	V	No load
Over power protection			<100	VA	Auto-restart
Dynamic step load (50%-100%-50%)			1.8	$V_{P-P}$	





### 3 Schematic

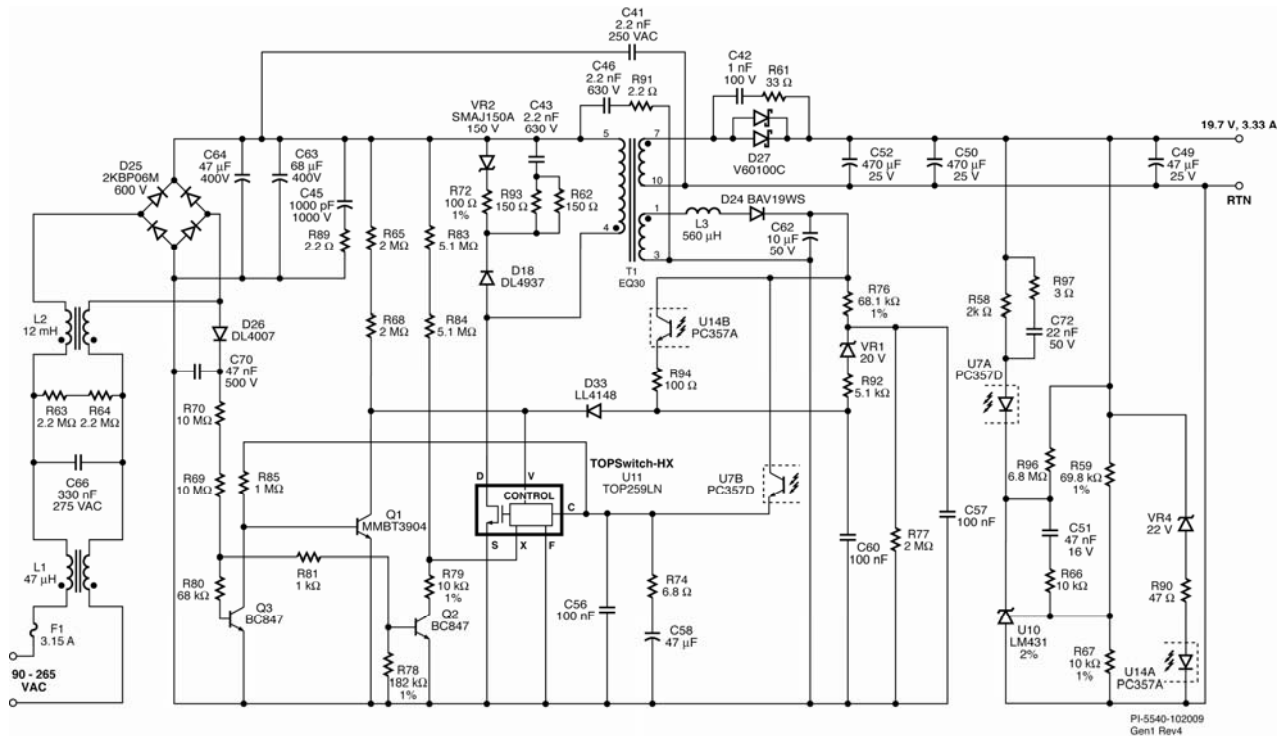


Figure 4 – Schematic.





## 4 Bill of Materials

Item	Qty	Ref Des	Description	Mfg Part Number	Mfg
1	1	C41	2.2 nF, Ceramic, Y1	440LD22-R	Vishay
2	1	C42	1 nF, 100 V, Ceramic, X7R, 0805	ECJ-2VB2A102K	Panasonic
3	1	C43 C46	2.2 nF, 630 V, Ceramic, X7R, 1206	ECJ-3FBJ222K	Panasonic
4	1	C45	1000 pF, 50 V, Ceramic, X7R, 1206	ECJ-3FB2J102K	Panasonic
5	1	C49	47 $\mu$ F, 25 V, Electrolytic, Very Low ESR, 300 m $\Omega$ , (5 x 11)	EKZE250ELL470ME11D	Nippon Chemi-Con
6	2	C50 C52	470 $\mu$ F, 25 V, Electrolytic, Very Low ESR, 39 m $\Omega$ , (10 x 13.5)	25VZLH47010X12.5	Rubycon
7	3	C56 C57 C60	100 nF 25 V, Ceramic, X7R, 0603	ECJ-1VB1E104K	Panasonic
8	1	C51	47 nF 16 V, Ceramic, X7R, 0603	ECJ-1VB1C473K	Panasonic
9	1	C58	47 $\mu$ F, 10 V, Tantalum Electrolytic, B Case, SMD	T491B476M010AS	Kemet
10	1	C62	10 $\mu$ F, 50 V, Electrolytic, Gen Purpose, (5 x 11)	ECA-1HHG100	Panasonic
11	1	C63	68 $\mu$ F, 400 V, Electrolytic, Low ESR, (12.5 x 40)	EPAG401ELL680MK40S	Nippon Chemi-Con
12	1	C64	47 $\mu$ F, 400 V, Electrolytic, Low ESR, (12.5 x 30)	EPAG401ELL470MK30S	Nippon Chemi-Con
13	1	C66	330 nF, 275 VAC, Film, X2	LE334-M	OKAYA
14	1	C70	47 nF, 500 V, Ceramic, X7R, 1812	VJ1812Y473KXEAT	Vishay
15	1	C72	22 nF, 50 V, Ceramic, X7R, 0805	ECJ-2VB1H223K	Panasonic
16	1	D18	600 V, 1 A, Rectifier, Fast Recovery, MELF (DL-41)	DL4937-13-F	Diodes Inc
17	1	D24	120 V, 0.2 A, Fast Switching, 50 ns, SOD-323	BAV19WS	Diode Inc.
18	1	D25	600 V, 2 A, Bridge Rectifier, Glass Passivated	2KBP06M	Vishay
19	1	D26	1000 V, 1 A, Rectifier, Glass Passivated, DO-213AA (MELF)	DL4007-13-F	Diodes Inc
20	1	D27	100 V, 60 A, Dual Schottky, TO-220AB	V60100C-E3/45	Vishay
21	1	D33	75 V, 0.15 A, Fast Switching, 4 ns, MELF	LL4148-13	Diode Inc.
22	1	F1	3.15 A, 250 V, Slow, RST	507-1181	Belfuse
23	1	L1	47 $\mu$ H, Common Mode Inductor, 4 Pins, Custom Common-mode Choke - refer to Specification of L1		
24	1	L2	12 mH,xA, Ferrite Toroid, 4 Pin, Custom Common-mode Choke - refer to Specification of L2		
25	1	L3	560 $\mu$ H, 0.23 A, 0805 SMD (optional)	LLQ2012_ER56K	Toko
26	1	Q1	NPN, Small Signal BJT, 40 V, 0.2 A, SOT-23	MMBT3904	Vishay
27	2	Q2 Q3	NPN, Small Signal BJT, 45 V, 0.1 A, SOT-23	BC847CWT1G	On Semi
28	1	R58	2 k $\Omega$ , 5%, 1/8 W, Metal Film, 0805	ERJ-6GEYJ202V	Panasonic
29	1	R59	69.8 k $\Omega$ , 1%, 1/8 W, Metal Film, 0805	ERJ-6ENF6982V	Panasonic
30	1	R61	33 $\Omega$ , 5%, 1/4 W, Metal Film, 1206	ERJ-8GEYJ330V	Panasonic
31	2	R62 R93	150 $\Omega$ , 5%, 1/4 W, Metal Film, 1206	ERJ-8GEYJ151V	Panasonic
32	2	R63 R64	2.2 M $\Omega$ , 5%, 1/4 W, Metal Film, 1206	ERJ-8GEYJ225V	Panasonic
33	2	R65 R68	2 M $\Omega$ , 5%, 1/4 W, Metal Film, 1206	ERJ-8GEYJ205V	Panasonic
34	4	R69 R70	10 M, 5%, 1/4 W, Metal Film, 1206	ERJ-8GEYJ106V	Panasonic
35	1	R66	10 k $\Omega$ , 5%, 1/10 W, Metal Film, 0603	ERJ-3GEYJ103V	Panasonic
36	1	R67	10 k $\Omega$ , 1%, 1/16 W, Metal Film, 0603	ERJ-3EKF1002V	Panasonic
37	1	R72	100 $\Omega$ , 1%, 1/4 W, Metal Film, 1206	ERJ-8ENF1000V	Panasonic
38	1	R74	6.8 $\Omega$ , 5%, 1/10 W, Metal Film, 0603	ERJ-3GEYJ685V	Panasonic



39	1	R76	68.1 k $\Omega$ , 1%, 1/8 W, Metal Film, 0805	ERJ-6ENF6812V	Panasonic
40	1	R77	2.00 M $\Omega$ , 1%, 1/16 W, Metal Film, 0603	ERJ-3EKF2004V	Panasonic
41	1	R78	182 k $\Omega$ , 5%, 1/10 W, Metal Film, 0603	ERJ-3GEYJ393V	Panasonic
42	1	R79	10.0 k $\Omega$ , 1%, 1/16 W, Metal Film, 0603	ERJ-6ENF1002V	Panasonic
43	1	R80	68 k $\Omega$ , 5%, 1/10 W, Metal Film, 0603	ERJ-3GEYJ683V	Panasonic
44	1	R81	1 k $\Omega$ , 5%, 1/10 W, Metal Film, 0603	ERJ-3GEYJ102V	Panasonic
45	2	R83 R84	5.1 M $\Omega$ , 5%, 1/4 W, Metal Film, 1206	ERJ-8GEYJ515V	Panasonic
46	1	R85	1 M $\Omega$ , 5%, 1/10 W, Metal Film, 0603	ERJ-3GEYJ105V	Panasonic
47	1	R89	2.2 R, 5%, 1/4 W, Metal Film, 1206	ERJ-8GEYJ2R2V	Panasonic
48	1	R90	47 $\Omega$ , 5%, 1/8 W, Metal Film, 0805	ERJ-6GEYJ470V	Panasonic
49	1	R91	2.2 $\Omega$ , 5%, 1/4 W, Metal Film, 1206	ERJ-8GEYJ2R2V	Panasonic
50	1	R92	5.1 k $\Omega$ , 5%, 1/10 W, Metal Film, 0603	ERJ-3GEYJ512V	Panasonic
51	1	R94	100 $\Omega$ , 5%, 1/10 W, Metal Film, 0805	ERJ-6GEYJ101V	Panasonic
52	1	R96	6.8 M $\Omega$ , 5%, 1/8 W, Metal Film, 0805	ERJ-6GEYJ685V	Panasonic
53	1	R97	3 $\Omega$ , 5%, 1/10 W, Metal Film, 0603	ERJ-3GEYJ3R0V	Panasonic
54	1	T1	Custom Transformer, EQ30, 10pins		
55	1	U10	IC, 2.495 V Shunt Regulator, SOT23	LM431AIM3D	National Semiconductor
56	1	U11	TOPSwitch-HX, TOP259LN, eSIP-7C	TOP259LN	Power Integrations
57	1	U14	Optocoupler, 80 V, CTR 4-Mini Flat	PC357N1TJ00F (Type A)	Sharp
58	1	U7	Optocoupler, 80 V, CTR 4-Mini Flat	PC357N3TJ00F (Type D)	Sharp
59	1	VR1	20 V, 5%, 150 mW, SSMINI-2	MAZS2000ML	Panasonic-SSG
60	1	VR2	150 V, 1 W, 11%, DO214AC (SMA)	SMAJ150A-13	Diodes, Inc
61	1	VR4	22 V, 5%, 150 mW, SSMINI-2	MAZS2200ML	Panasonic-SSG



## 5 Circuit Description

This adapter power supply employs the TOPSwitch TOP259LN (U11), with an integrated high voltage MOSFET and a PWM controller, in a flyback configuration. The TOP259LN regulates the output by adjusting the duty cycle based on the current into its CONTROL (C) pin. The power supply output voltage is sensed on the secondary side by shunt regulator U10 and provides a feedback signal to the primary side through optocoupler U7.

### 5.1 Energy Efficiency

The EcoSmart<sup>®</sup> feature of U11 provides constant efficiency over the entire load range. The proprietary Multi-cycle Modulation function automatically achieves this performance, eliminating special operating modes triggered at specific loads, which greatly simplifies circuit design.

### 5.2 Startup and Power Down

The line-sensing network formed by D26 and C70 provides input voltage information without the long time constant incurred by detecting the voltage across bulk input capacitors C63 and C64. This supports the advanced power up, power down, and reset behaviors provided by U11.

#### 5.2.1 Normal Input Voltage Range

While the input voltage is within normal operating range, Q3 pulls the base of Q1 down, keeping Q1 off. The point at which U11 begins to switch is therefore determined by the combination of resistors R65 and R68, and the 25  $\mu$ A UV threshold of U11's VOLTAGE MONITOR (V) pin. IC U11 switches once current into the V pin exceeds 25  $\mu$ A (at a line voltage of 100 VDC or approximately 72 VAC). Transistor Q2 provides a defined lower UV threshold that disables U11 when the AC is removed. When Q2 is off the X pin floats, keeping U11 disabled. This prevents output glitches that may otherwise occur due to C63 and C64 discharging when the AC input is cycled to reset U11 after latching shutdown. Resistor divider R70, R69, R81, and R78 determines the point at which Q2 turns on to enable U11 and start operation when the UV threshold at the V pin is exceeded.

#### 5.2.2 AC Loss (Power Down)

During power down, the power supply operates until output regulation is lost and does not restart until the UV threshold is once again exceeded. This prevents glitches on the output during power down.

### 5.3 Fast AC reset

Once U11 enters latching shutdown, removal of the input AC is necessary to reset U11. Removal of the input AC turns off Q3, turns on Q1, and pulls the V pin below the reset threshold. Reapplying AC at a level to exceed the UV threshold restarts the supply.



#### **5.4 Output Overload Shutdown**

This power supply has a time-triggered overload protection function sensed from the primary-side bias winding. During overload the voltage across C62 rises. Once it exceeds approximately 20 V, it triggers the shutdown feature on the V pin. The values of C57, R76, and R77 set the value of the delay, before shutdown is triggered.

#### **5.5 Output Power Limiting with Line Voltage**

To provide constant output power with varying line voltage, R83, R84, and R79 reduce the internal current limit of U11 as the line voltage increases. This allows the supply to limit the output power to <100 VA at high line and deliver the rated output power at low line.

#### **5.6 Output Over-voltage Protection and Fast AC Reset**

Open-loop faults cause the output voltage to rise and exceed the specified maximum value. To keep output voltages below the specified maximum during such fault conditions, a simple latching shutdown is implemented by VR4 and U14. When the output reaches approximately 23 V, U14 conducts and current into the V pin exceeds the latching shutdown current threshold. This shuts down the supply.

Once the power supply goes through the latch-off process, to reset it immediately, cycle the AC input.

#### **5.7 Thermal Overload Protection**

IC U11 has an integrated, 100% tested, accurate hysteretic thermal-overload protection feature. If the junction temperature reaches +142 °C (during a fault condition), U11 shuts down. It automatically recovers once the junction temperature has decreased by approximately 75 °C.



## 6 PCB Layout

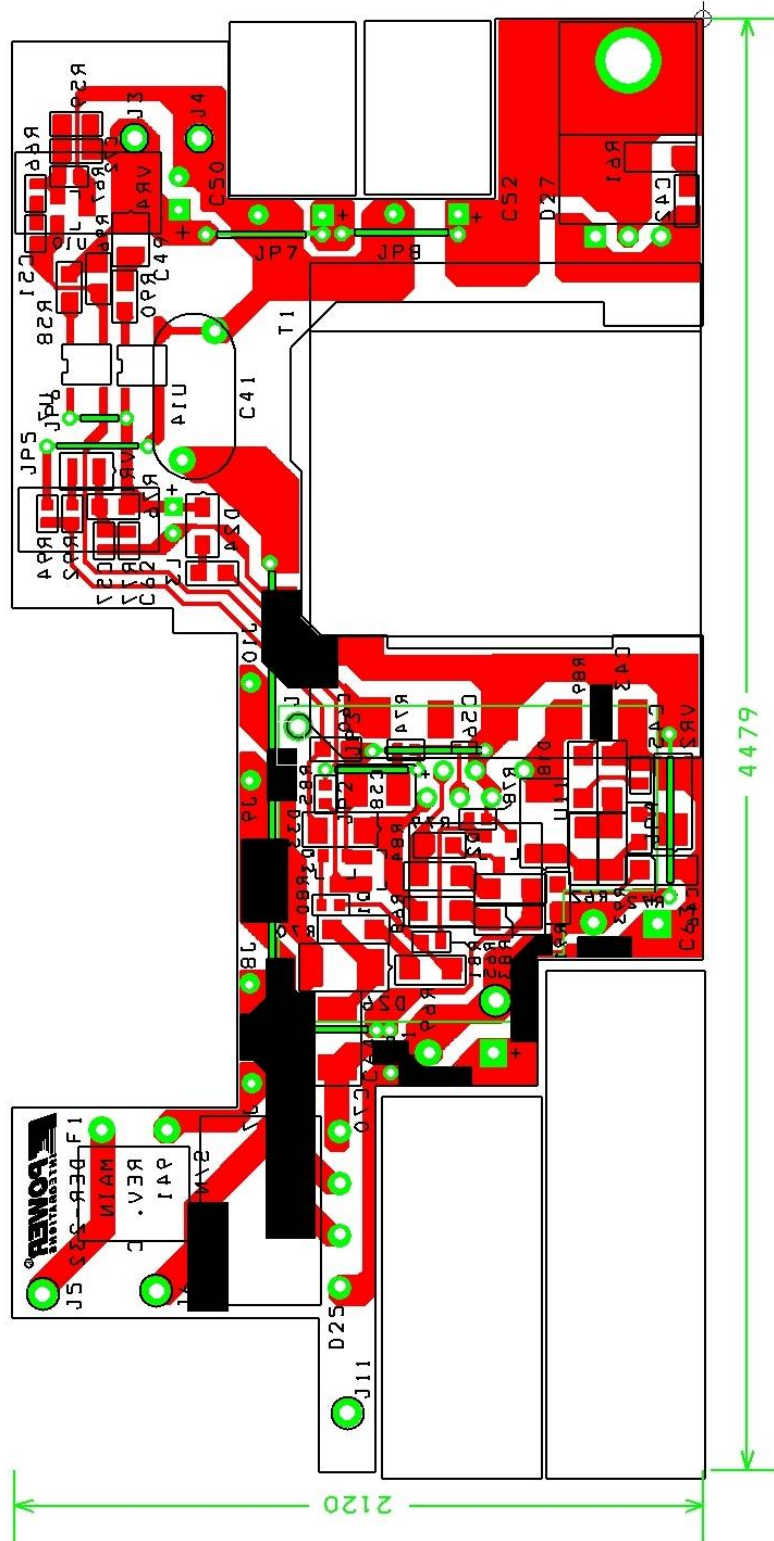


Figure 5 – Power Supply PCB (115 mm x 55 mm).



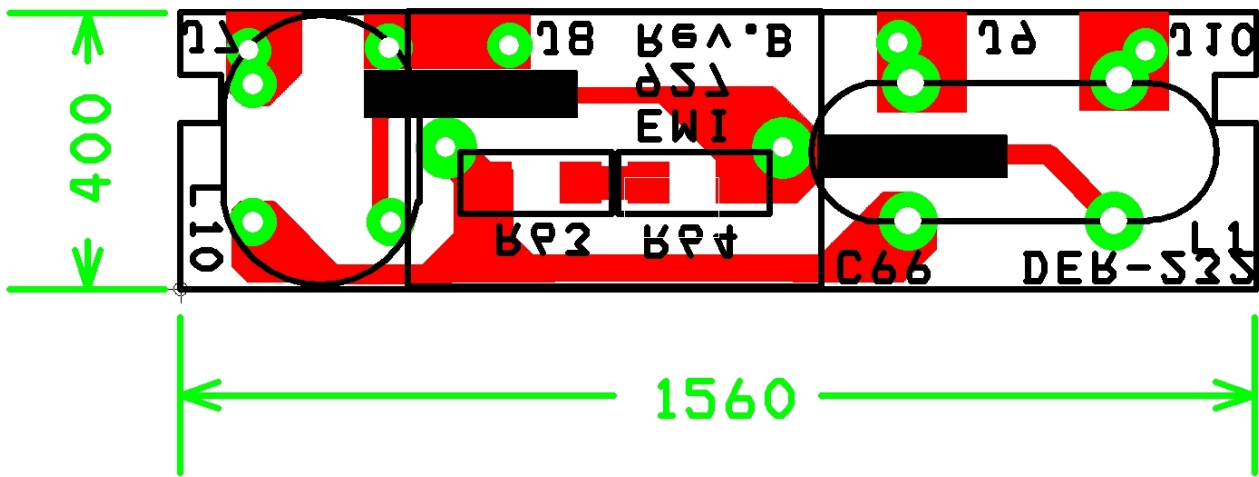


Figure 6 – EMI Filter Daughter Board PCB.

## 7 Transformer Specifications

### 7.1 Electrical Diagram

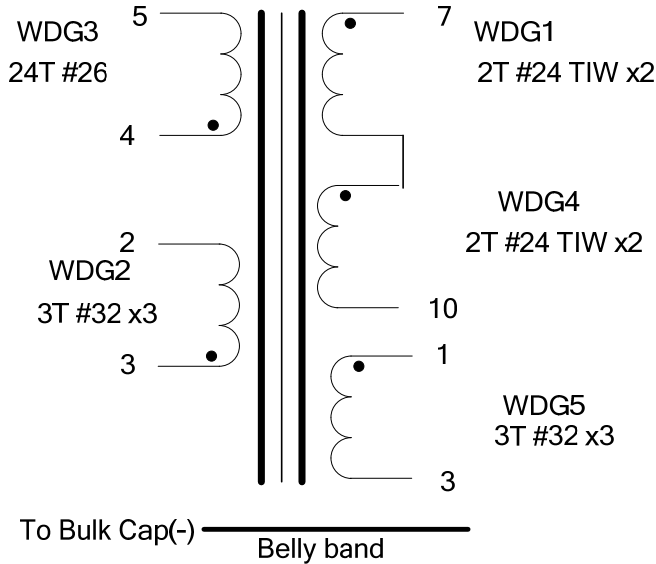


Figure 7 – Transformer Electrical Diagram.

### 7.2 Electrical Specifications

<b>Electrical Strength</b>	1 second, 60 Hz, from pins 1–5 to pins 6–10	3000 VAC
<b>Primary Inductance</b>	Pins 4–5, all other windings open, measured at 100 kHz, 0.4 VRMS	355 - 400 $\mu$ H
<b>Resonant Frequency</b>	Pins 1–3, all other windings open	1000 kHz (Min.)
<b>Primary Leakage Inductance</b>	Pins 4–5, with pins 7-10 shorted, measured at 100 kHz, 0.4 VRMS	6 $\mu$ H (Max.)

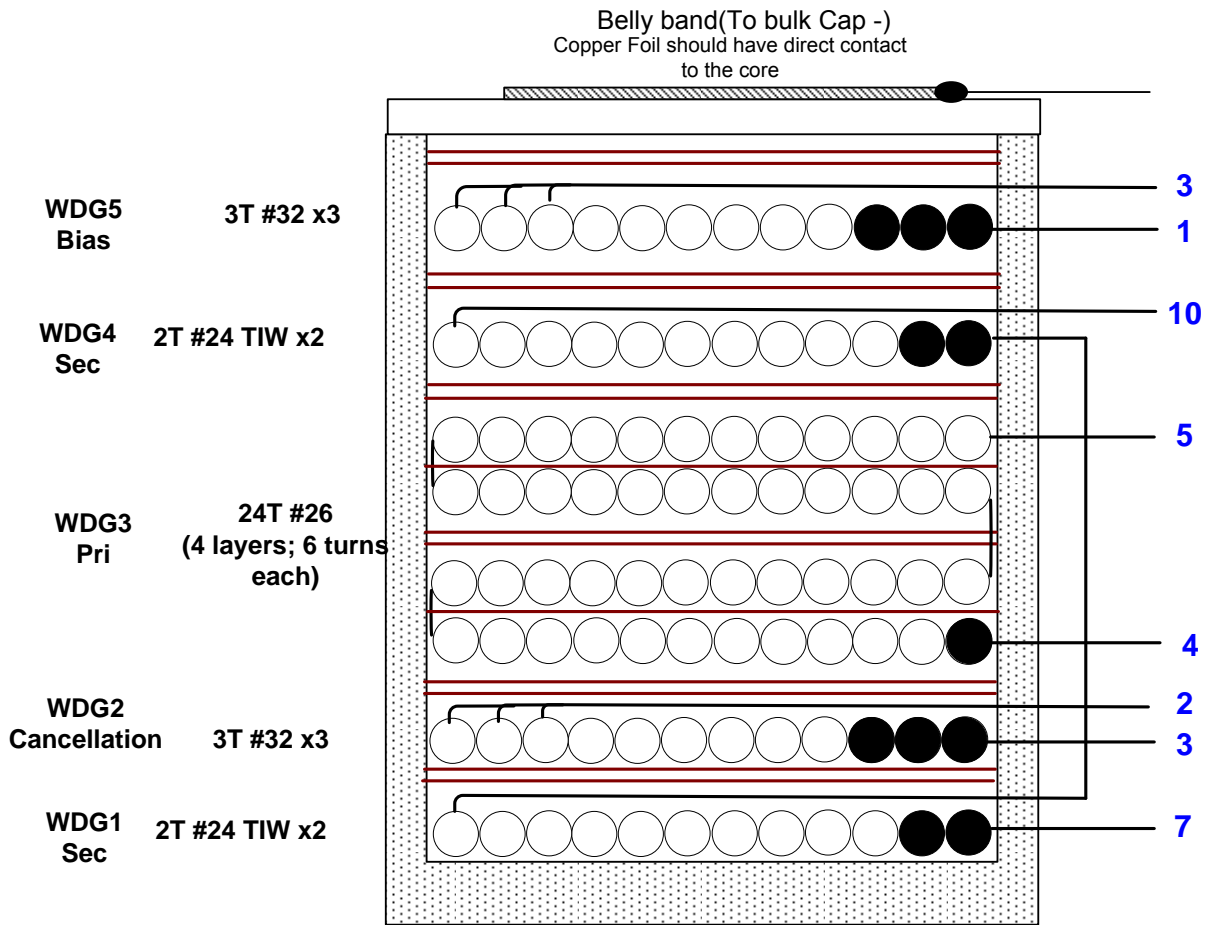
### 7.3 Materials

Item	Description
[1]	Core: 3F35 Ferroxcube EQ30, PLT30/20/3 AL=4600 nH/T <sup>2</sup> (UNGAPPED)
[2]	Bobbin: PIEQ30 (Power Integrations Slimcore™ bobbin: PIP/N 25-00887-00) Vertical, 5–5 pins
[3]	Magnet Wire: #32 AWG
[4]	Magnet Wire: #26 AWG
[5]	Magnet Wire: #24 AWG Triple-insulated Wire
[6]	Tape: 3M 1298 Polyester Film, 3.5 mm width
[7]	Tape: Copper foil 2 mil, 10 mm width
[8]	Varnish

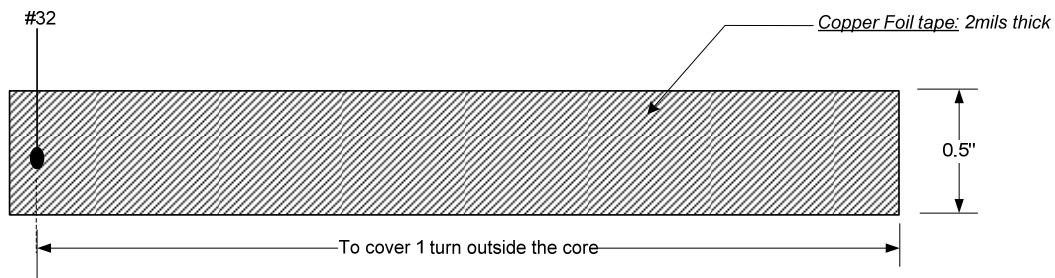




**7.4 Transformer Build Diagram**



**Figure 8 – Transformer Build Diagram.**



**Figure 9 – Shield.**

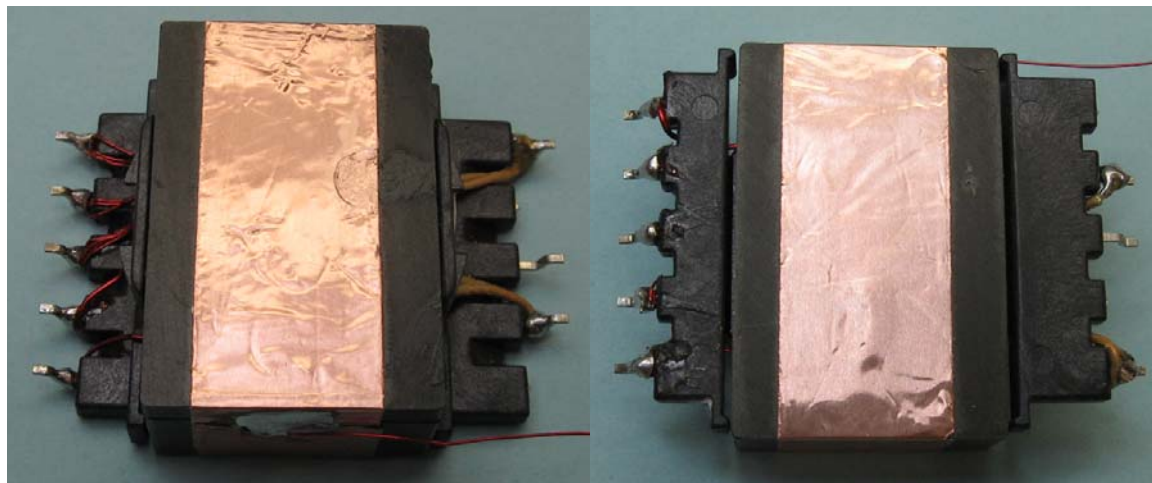


### 7.5 Transformer Construction

<b>Winding preparation</b>	Position the bobbin such that the pins are on the right side of the bobbin chuck. Machine rotates in forward direction. Pin numbers are shown in illustrations.
<b>WDG1 1<sup>st</sup> half secondary</b>	Start at pin 7; wind with firm tension 2 turns bifilar of item [5] from right to left, and leave about 8" of wires for 2 <sup>nd</sup> half secondary at pin 9 position.
<b>Insulation</b>	2 layers of tape [6] for insulation.
<b>WDG 2 Cancellation</b>	Start at pin 3; wind 3 trifilar turns of item [3], with firm tension, from right to left. Finish at pin 2.
<b>Insulation</b>	2 layers of tape [6] for insulation.
<b>WDG3</b>	Start at Pin 4; wind with firm tension 6 turns of item [4] from right to left for the 1 <sup>st</sup> layer. Add one layer insulation tape; continue winding remaining 6 turns from left to right for the 2 <sup>nd</sup> layer. Add two layer insulation tape; continue wind with firm tension 6 turns of item [4] from right to left for the 3 <sup>rd</sup> layer. Add one layer insulation tape; continue winding remaining 6 turns from left to right for the 4 <sup>th</sup> layer Finish at pin 5.
<b>Insulation</b>	2 Layers of tape [6] for insulation.
<b>WDG4 2<sup>nd</sup> half secondary</b>	Continue with floating wires from WD1; wind with firm tension 2 turns bifilar of item [5] from right to left. Finish at pin 10.
<b>Insulation</b>	2 Layers of tape [6] for insulation.
<b>WDG5 Bias</b>	Start at pin 1; wind 3 trifilar turns of item [3], with firm tension, from right to left. Finish at pin 3.
<b>Insulation</b>	2 layers of tape [6] for insulation.
<b>Assemble core</b>	Grind, assemble, secure the cores with glue and belly tape.
<b>Belly Band</b>	Wrap core with item [7], solder wire to the side of the foil. This wire will be terminated to the bulk (-) of capacitor.
<b>Finish</b>	Wrap cores with belly band (see fig. 9). Solder with magnet wire #32 AWG. Cut pins 6 and 9. (See illustrations). Varnish transformer assembly.



## 7.6 Completed Transformer



**Figure 10** – Completed Transformer; Top (Right) and Bottom (Left) Views.


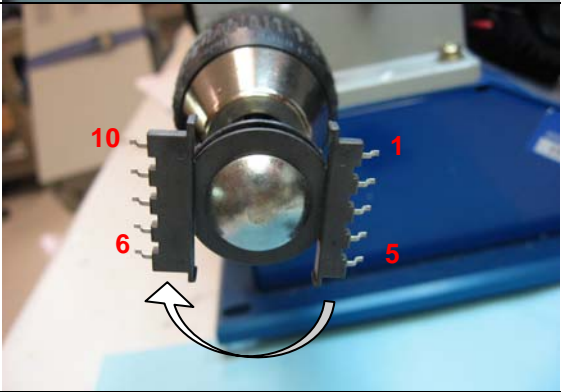
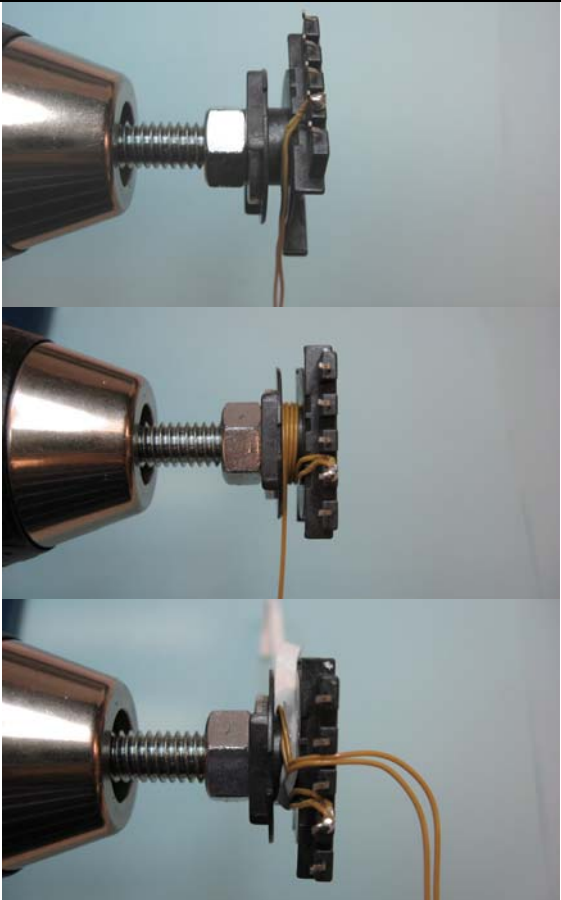


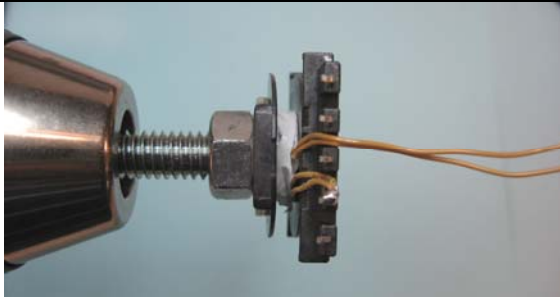
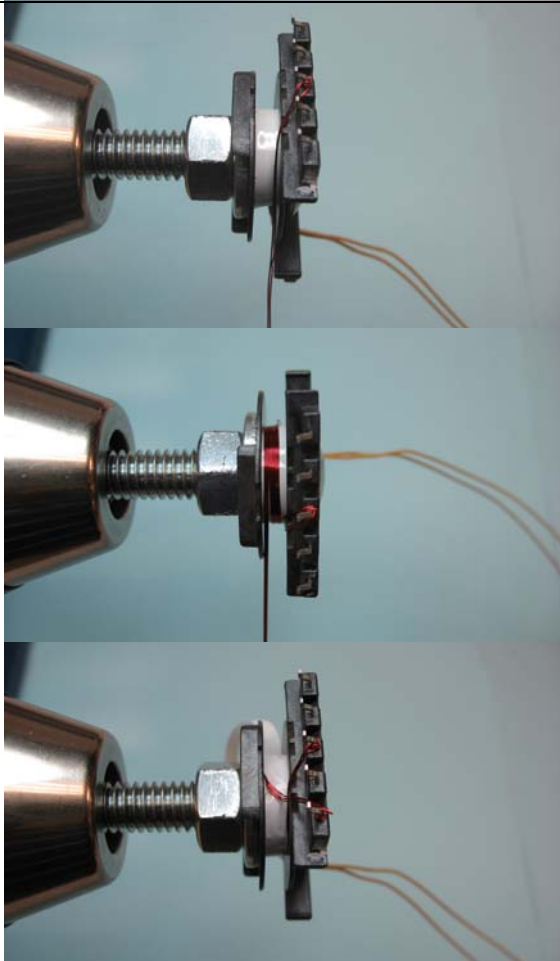
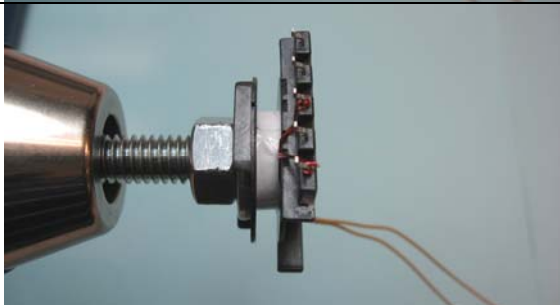
**Figure 11** – Transformer Materials Showing EQ30, PLT30 Core, and Ultra-low Profile Wire-wound Bobbin.



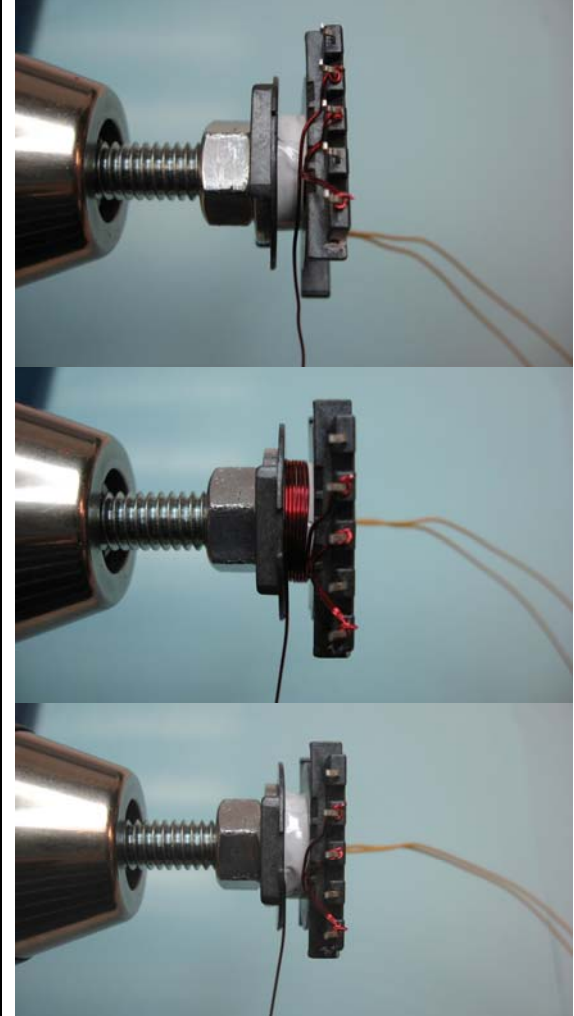
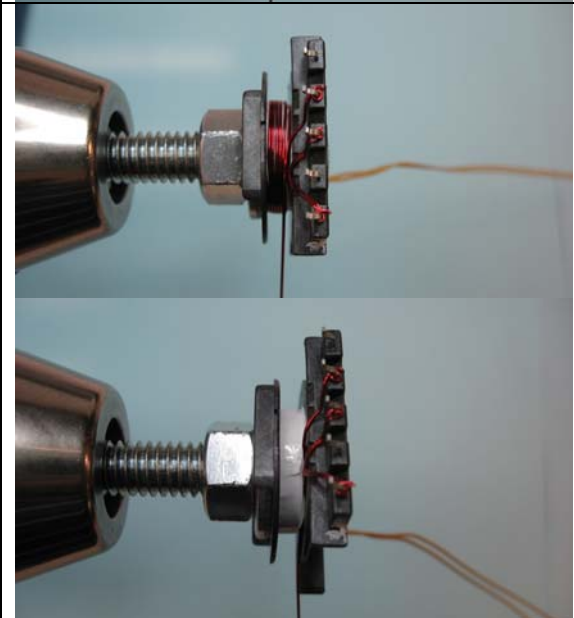
**Figure 12** – Measured Height of the Complete Transformer.

**7.7 Transformer Winding Illustrations**

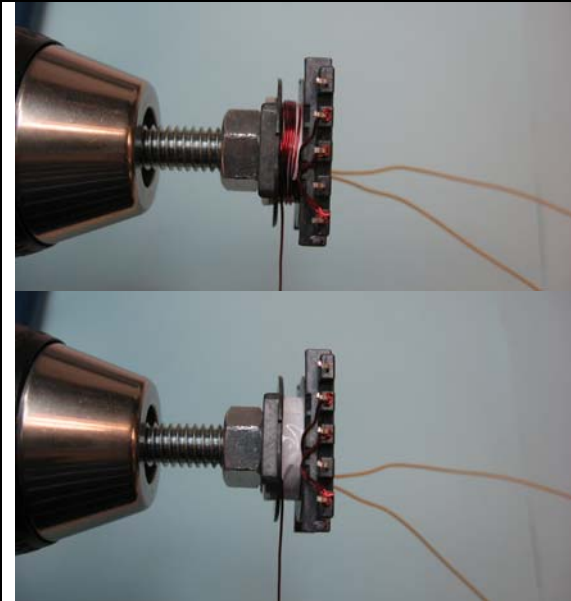
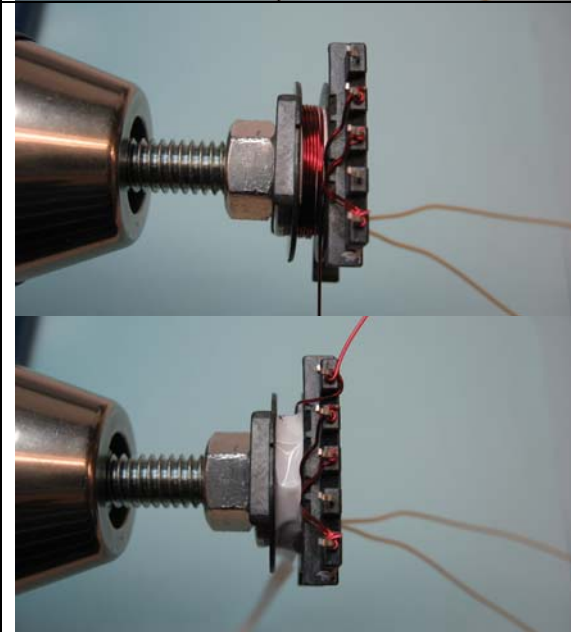
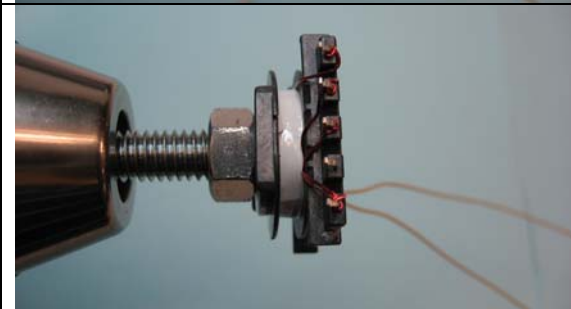
<p><b>Winding preparation</b></p>		<p>Position the bobbin such that the pins are on the right side of the bobbin chuck. Machine rotates in forward direction.</p>
		<p>Pin-out is numbered as shown in this picture and in clockwise direction.</p>
<p><b>WDG1 1<sup>st</sup> half secondary</b></p>		<p>Start at pin 7; wind with firm tension 2 turns bifilar of item [5] from right to left, and leave about 8" of wires for 2<sup>nd</sup> half secondary at pin 9 position.</p>

<p><b>Insulation</b></p>		<p>2 layers of tape [6] for insulation.</p>
<p><b>WDG 2 Cancellation</b></p>		<p>Start at pin 3; wind 3 trifilar turns of item [3], with firm tension, from right to left. Finish at pin 2.</p>
<p><b>Insulation</b></p>		<p>2 layers of tape [6] for insulation.</p>



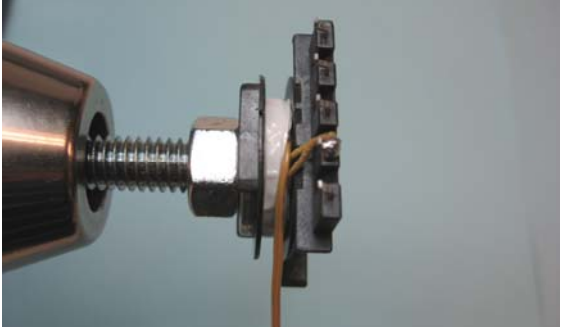
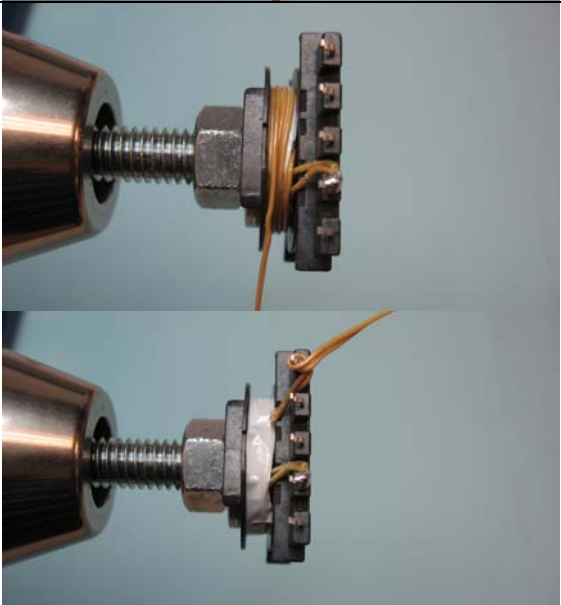
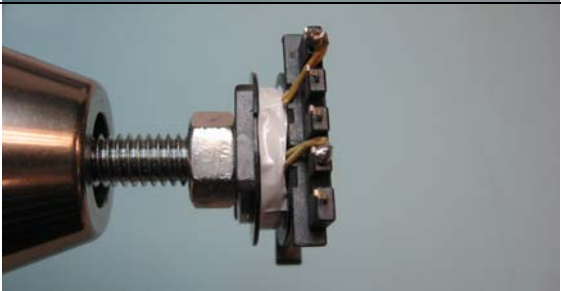
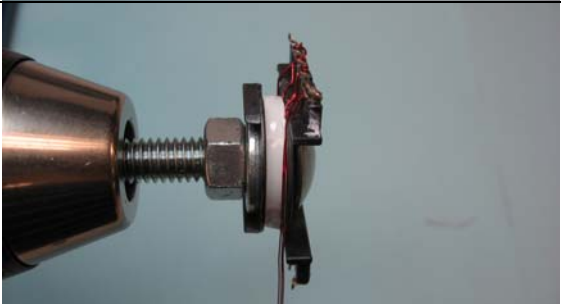
<p><b>WDG3</b></p>		<p>Start at pin 4; wind with firm tension 6 turns of item [4] from right to left for the 1<sup>st</sup> layer. Add one layer insulation tape;</p>
<p><b>WDG3 (Cont'd)</b></p>		<p>Continue winding remaining 6 turns from left to right for the 2<sup>nd</sup> layer. Add two layer insulation tape; continue winding with firm tension 6 turns of item [4] from right to left for the 3<sup>rd</sup> layer. Add one layer insulation tape;</p>



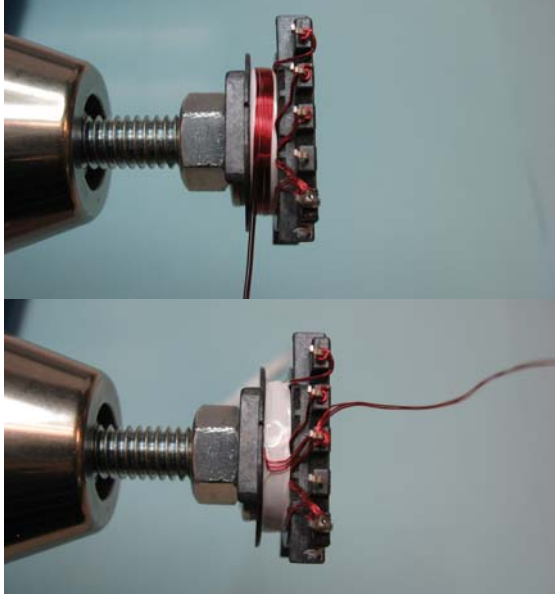

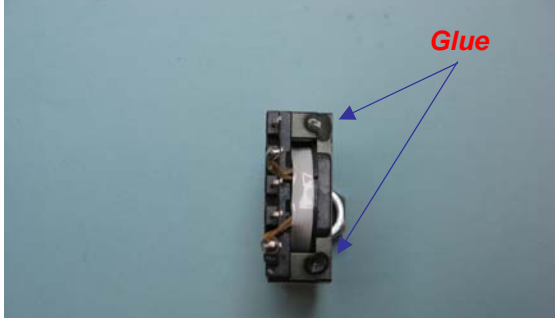

		
<p><b>WDG3 (Cont'd)</b></p>		<p>Continue winding remaining 6 turns from left to right for the 4<sup>th</sup> layer. Finish at pin 5.</p>
<p><b>Insulation</b></p>		<p>2 layers of tape [6] for insulation.</p>





<p><b>WDG4</b> 2<sup>nd</sup> half secondary</p>		<p>Continue with floating wires from WD1;</p>
<p><b>WDG4</b> 2<sup>nd</sup> half secondary (Cont'd)</p>		<p>Wind with firm tension 2 turns bifilar of item [5] from right to left. Finish at pin 10.</p>
<p><b>Insulation</b></p>		<p>2 layers of tape [6] for insulation.</p>
<p><b>WDG5</b> Bias</p>		<p>Start at pin 1; wind 3 trifilar turns of item [3], with firm tension, from right to left. Finish at pin 3.</p>



<p><b>WDG5 Bias (Cont'd)</b></p>		<p>Wind 3 trifilar turns of item [3], with firm tension, from right to left. Finish at pin 3.</p>
<p><b>Insulation</b></p>		<p>2 layers of tape [6] for insulation.</p>
<p><b>Assemble core</b></p>		<p>Grind, assemble, secure the cores with glue.</p>
<p><b>Finish.</b></p>		<p>Wrap cores with belly band (see fig. 3). Solder with magnet wire #32 AWG. See this picture. Cut pins 6 and 9. Varnish transformer assembly.</p>



**7.8 Common-mode Choke Specifications (L1)**

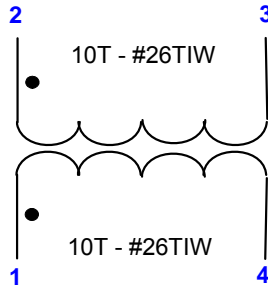


Figure 13 – CMC Electrical Diagram.

**7.9 Electrical Specifications**

Inductance (LCM)	Pins 1–4 or 2–3. measured at 100 kHz	47 $\mu$ H $\pm$ 10%
Leakage (LL)	Pins 1–4 with pins 2–3 shorted or versa at 100 kHz	0.5 $\mu$ H (max) $\pm$ 20%
Core Effective Inductance		460 nH/N <sup>2</sup>

**7.10 Materials**

Item	Description
[1]	Toroid Core: K5B T10X5X5 (King Core); PI P/N 32-00086-00
[2]	Magnet Wire: #26 AWG, Triple-insulated Wire.

**7.11 Winding Instructions**

- Use 1 ft of item [2], start at pin 1 and 2 wind 10 turns end at pin 4 and 3.

**7.12 Illustrations**

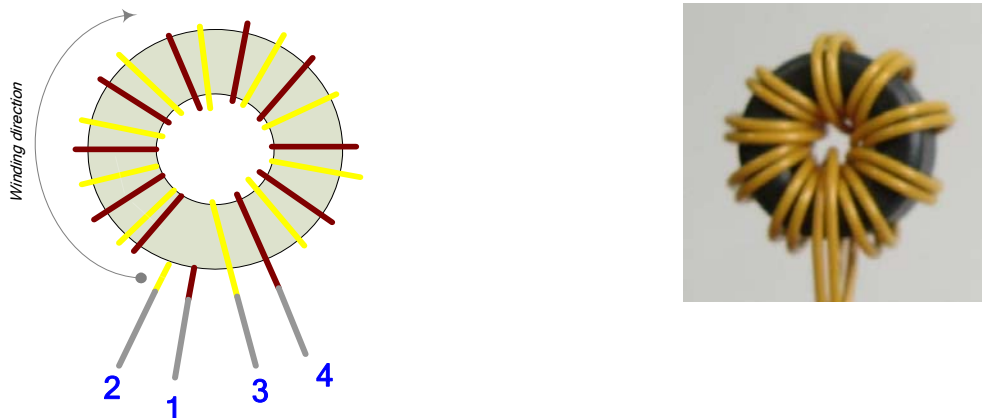


Figure 14 – CMC Build Illustration.



### 7.13 Common-mode Choke Specifications (L2)

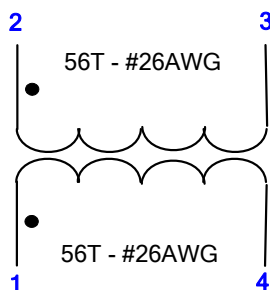


Figure 15 – CMC Electrical Diagram.

### 7.14 Electrical Specifications

Inductance (LCM)	Pins 1–4 or 2–3. measured at 100 kHz	12 mH ±10%
Leakage (LL)	Pins 1–4 with pins 2–3 shorted or versa at 100 kHz	80 μH (max) ±20%
Core Effective Inductance		3795 nH/N <sup>2</sup>

### 7.15 Materials

Item	Description
[1]	Toroid Core: MN-ZN T14X9X5 R10K U1000; Dimension: OD:14.35 mm / ID:7.5 mm / HT:5.3 mm
[2]	Magnet Wire: #26 AWG, Heavy Nyleze

### 7.16 Winding Instructions

- Use 4 ft of item [2], start at pin 1 wind 56 turns end at pin 4.
- Do the same for another half of Toroid, start at pin 2 and end at pin 3.

### 7.17 Illustrations

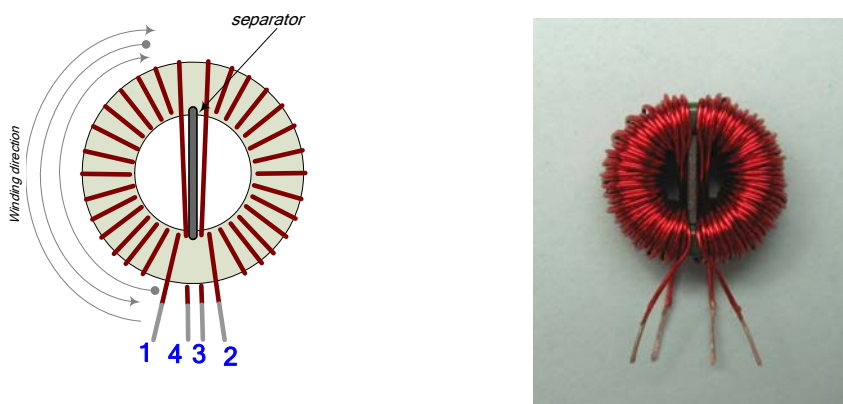


Figure 16 – CMC Build Illustration.

## 8 Transformer Design Spreadsheet

ACDC_TOPSwitchHX_021308; Rev.1.8; Copyright Power Integrations 2008	INPUT	INFO	OUTPUT	UNIT	TOP_HX_021308: TOPSwitch-HX Continuous/Discontinuous Flyback Transformer Design Spreadsheet
<b>ENTER APPLICATION VARIABLES</b>					
VACMIN	90			Volts	Minimum AC Input Voltage
VACMAX	265			Volts	Maximum AC Input Voltage
fL	50			Hertz	AC Mains Frequency
VO	19.50			Volts	Output Voltage (main)
PO_AVG	65.00			Watts	Average Output Power
PO_PEAK	65.00		65.00	Watts	Peak Output Power
n	0.85			%/100	Efficiency Estimate
Z	0.50				Loss Allocation Factor
VB	15			Volts	Bias Voltage
tC	3.00			mSeconds	Bridge Rectifier Conduction Time Estimate
CIN	115.0		115	uFarads	Input Filter Capacitor
<b>ENTER TOPSWITCH-HX VARIABLES</b>					
<b>TOPSwitch-HX</b>	<b>TOP259LN</b>			Universal / Peak	115 Doubled/230V
<i>Chosen Device</i>		<i>TOP259LN</i>	Power Out	254 W / 254 W	333W
KI	0.32				External Ilimit reduction factor (KI=1.0 for default ILIMIT, KI <1.0 for lower ILIMIT)
ILIMITMIN_EXT			2.202	Amps	Use 1% resistor in setting external ILIMIT
ILIMITMAX_EXT			2.534	Amps	Use 1% resistor in setting external ILIMIT
Frequency (F)=132kHz, (H)=66kHz	<b>F</b>		F		Select 'H' for Half frequency – 66 kHz, or 'F' for Full frequency – 132 kHz
fS			132000	Hertz	TOPSwitch-HX Switching Frequency: Choose between 132 kHz and 66 kHz
fSmin			119000	Hertz	TOPSwitch-HX Minimum Switching Frequency
fSmax			145000	Hertz	TOPSwitch-HX Maximum Switching Frequency
High Line Operating Mode			FF		Full Frequency, Jitter enabled
VOR	120.00			Volts	Reflected Output Voltage
VDS			10	Volts	TOPSwitch on-state Drain-to- Source Voltage
VD	0.50			Volts	Output Winding Diode Forward Voltage Drop
VDB	0.70			Volts	Bias Winding Diode Forward Voltage Drop
KP	0.55				Ripple-to-Peak Current Ratio (0.3 < KRP < 1.0 : 1.0 < KDP < 6.0)
<b>PROTECTION FEATURES</b>					
<b>LINE SENSING</b>					
VUV_STARTUP			101	Volts	Minimum DC Bus Voltage at which the power supply will



					start-up
VOV_SHUTDOWN			490	Volts	Typical DC Bus Voltage at which power supply will shut-down (Max)
RLS			4.4	M-ohms	Use two standard, 2.2 M-Ohm, 5% resistors in series for line sense functionality.
<b>OUTPUT OVERVOLTAGE</b>					
VZ			27	Volts	Zener Diode rated voltage for Output Overvoltage shutdown protection
RZ			5.1	k-ohms	Output OVP resistor. For latching shutdown use 20 ohm resistor instead
<b>OVERLOAD POWER LIMITING</b>					
Overload Current Ratio at VMAX			1.2		Enter the desired margin to current limit at VMAX. A value of 1.2 indicates that the current limit should be 20% higher than peak primary current at VMAX
Overload Current Ratio at VMIN			1.07		Margin to current limit at low line.
ILIMIT_EXT_VMIN			2.04	A	Peak primary Current at VMIN
ILIMIT_EXT_VMAX			1.89	A	Peak Primary Current at VMAX
RIL			17.14	k-ohms	Current limit/Power Limiting resistor.
RPL			N/A	M-ohms	Resistor not required. Use RIL resistor only
<b>ENTER TRANSFORMER CORE/CONSTRUCTION VARIABLES</b>					
<b>Core Type</b>	<b>Auto</b>		EI30		Core Type
Core			EQ30	P/N:	PC40EI30-Z
Bobbin			EQ30_BOBBIN	P/N:	BE-30-1112CP
AE	1.0800		1.08	cm <sup>2</sup>	Core Effective Cross Sectional Area
LE	3.6200		3.62	cm	Core Effective Path Length
AL	4600.0		4600	nH/T <sup>2</sup>	Ungapped Core Effective Inductance
BW	3.5		3.5	mm	Bobbin Physical Winding Width
M	0.00			mm	Safety Margin Width (Half the Primary to Secondary Creepage Distance)
L	4.00				Number of Primary Layers
NS	4		4		Number of Secondary Turns
<b>DC INPUT VOLTAGE PARAMETERS</b>					
VMIN			83	Volts	Minimum DC Input Voltage
VMAX			375	Volts	Maximum DC Input Voltage
<b>CURRENT WAVEFORM SHAPE PARAMETERS</b>					
DMAX			0.62		Maximum Duty Cycle (calculated at PO_PEAK)
IAVG			0.92	Amps	Average Primary Current (calculated at average output power)
IP			2.04	Amps	Peak Primary Current (calculated at Peak output power)
IR			1.12	Amps	Primary Ripple Current (calculated at average output)



					power)
IRMS			1.20	Amps	Primary RMS Current (calculated at average output power)
<b>TRANSFORMER PRIMARY DESIGN PARAMETERS</b>					
LP			378	uHenries	Primary Inductance
LP Tolerance	6		6		Tolerance of Primary Inductance
NP			24		Primary Winding Number of Turns
NB			3		Bias Winding Number of Turns
ALG			657	nH/T <sup>2</sup>	Gapped Core Effective Inductance
BM			2983	Gauss	Maximum Flux Density at PO, VMIN (BM<3000)
BP			3920	Gauss	Peak Flux Density (BP<4200) at ILIMITMAX and LP_MAX. Note: Recommended values for adapters and external power supplies <=3600 Gauss
BAC			820	Gauss	AC Flux Density for Core Loss Curves (0.5 X Peak to Peak)
ur			1227		Relative Permeability of Ungapped Core
LG			0.18	mm	Gap Length (Lg > 0.1 mm)
BWE			14	mm	Effective Bobbin Width
OD			0.58	mm	Maximum Primary Wire Diameter including insulation
INS			0.07	mm	Estimated Total Insulation Thickness (= 2 * film thickness)
DIA			0.51	mm	Bare conductor diameter
AWG			24	AWG	Primary Wire Gauge (Rounded to next smaller standard AWG value)
CM			406	Cmils	Bare conductor effective area in circular mils
CMA			340	Cmils/Amp	Primary Winding Current Capacity (200 < CMA < 500)
Primary Current Density (J)			5.84	Amps/mm <sup>2</sup>	Primary Winding Current density (3.8 < J < 9.75)
<b>TRANSFORMER SECONDARY DESIGN PARAMETERS (SINGLE OUTPUT EQUIVALENT)</b>					
<b>Lumped parameters</b>					
ISP			12.26	Amps	Peak Secondary Current
ISRMS			5.60	Amps	Secondary RMS Current
IO_PEAK			3.33	Amps	Secondary Peak Output Current
IO			3.33	Amps	Average Power Supply Output Current
IRIPPLE			4.50	Amps	Output Capacitor RMS Ripple Current
CMS			1119	Cmils	Secondary Bare Conductor minimum circular mils
AWGS			19	AWG	Secondary Wire Gauge (Rounded up to next larger standard AWG value)
DIAS			0.91	mm	Secondary Minimum Bare Conductor Diameter
ODS			0.88	mm	Secondary Maximum Outside Diameter for Triple Insulated Wire
INSS			-0.02	mm	Maximum Secondary Insulation





					Wall Thickness
<b>VOLTAGE STRESS PARAMETERS</b>					
VDRAIN			611	Volts	Maximum Drain Voltage Estimate (Includes Effect of Leakage Inductance)
PIVS			82	Volts	Output Rectifier Maximum Peak Inverse Voltage
PIVB			64	Volts	Bias Rectifier Maximum Peak Inverse Voltage
<b>TRANSFORMER SECONDARY DESIGN PARAMETERS (MULTIPLE OUTPUTS)</b>					
<b>1st output</b>					
VO1			19.5	Volts	Output Voltage
IO1_AVG			3.33	Amps	Average DC Output Current
PO1_AVG			65.00	Watts	Average Output Power
VD1			0.5	Volts	Output Diode Forward Voltage Drop
NS1			4.00		Output Winding Number of Turns
ISRMS1			5.597	Amps	Output Winding RMS Current
IRIPPLE1			4.50	Amps	Output Capacitor RMS Ripple Current
PIVS1			82	Volts	Output Rectifier Maximum Peak Inverse Voltage
CMS1			1119	Cmils	Output Winding Bare Conductor minimum circular mils
AWGS1			19	AWG	Wire Gauge (Rounded up to next larger standard AWG value)
DIAS1			0.91	mm	Minimum Bare Conductor Diameter
ODS1			0.88	mm	Maximum Outside Diameter for Triple Insulated Wire
<b>Total Continuous Output Power</b>			65	Watts	Total Continuous Output Power
Negative Output			N/A		If negative output exists enter Output number; eg: If VO2 is negative output, enter 2



## 9 Mechanical Drawings

The following mechanical drawings are for the custom mechanical designs used in this power supply.

### 9.1 Heat Spreader - Main

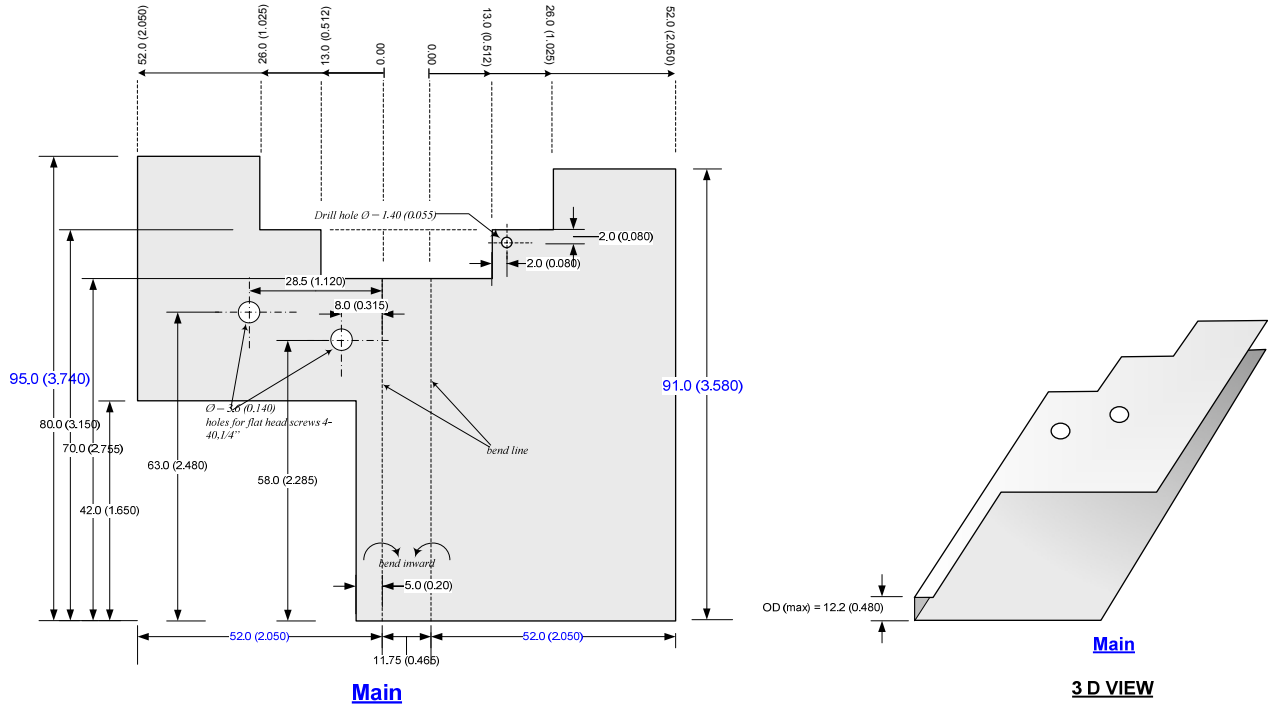
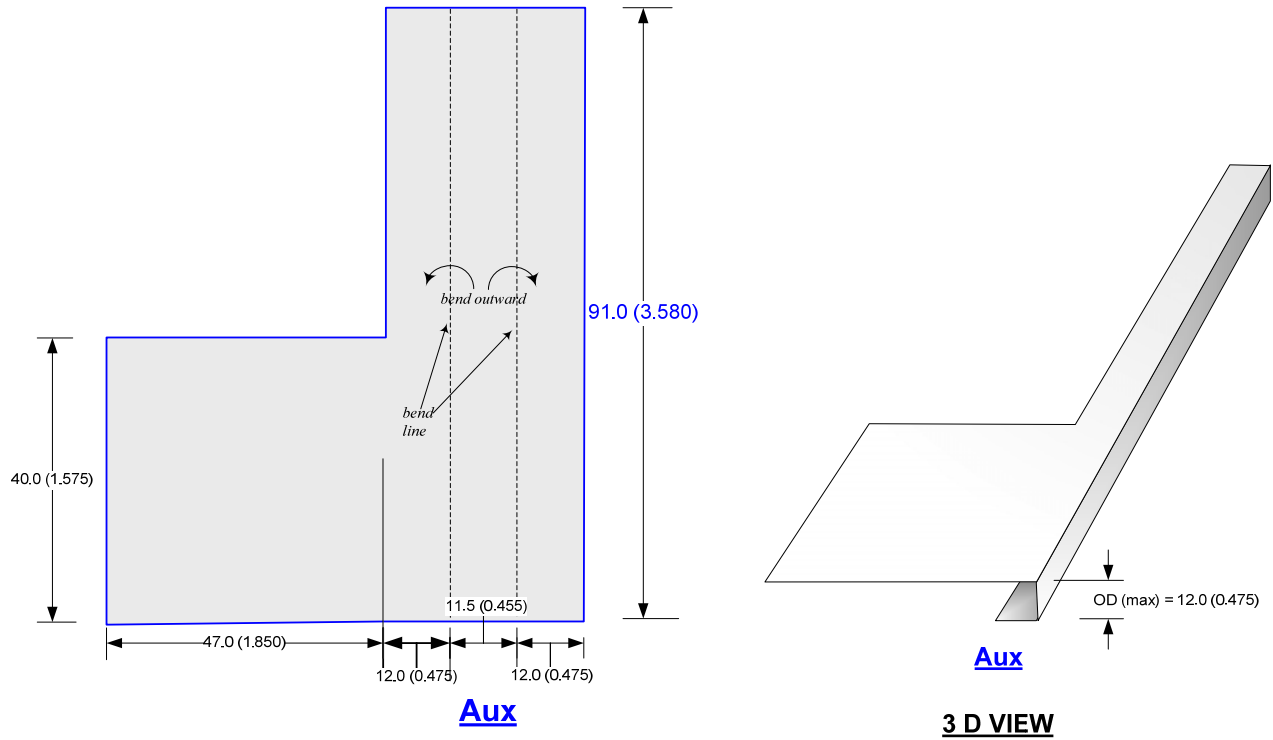


Figure 17 – Aluminum Heat-Spreader - Main.



### 9.2 Heat Spreader - Auxillary

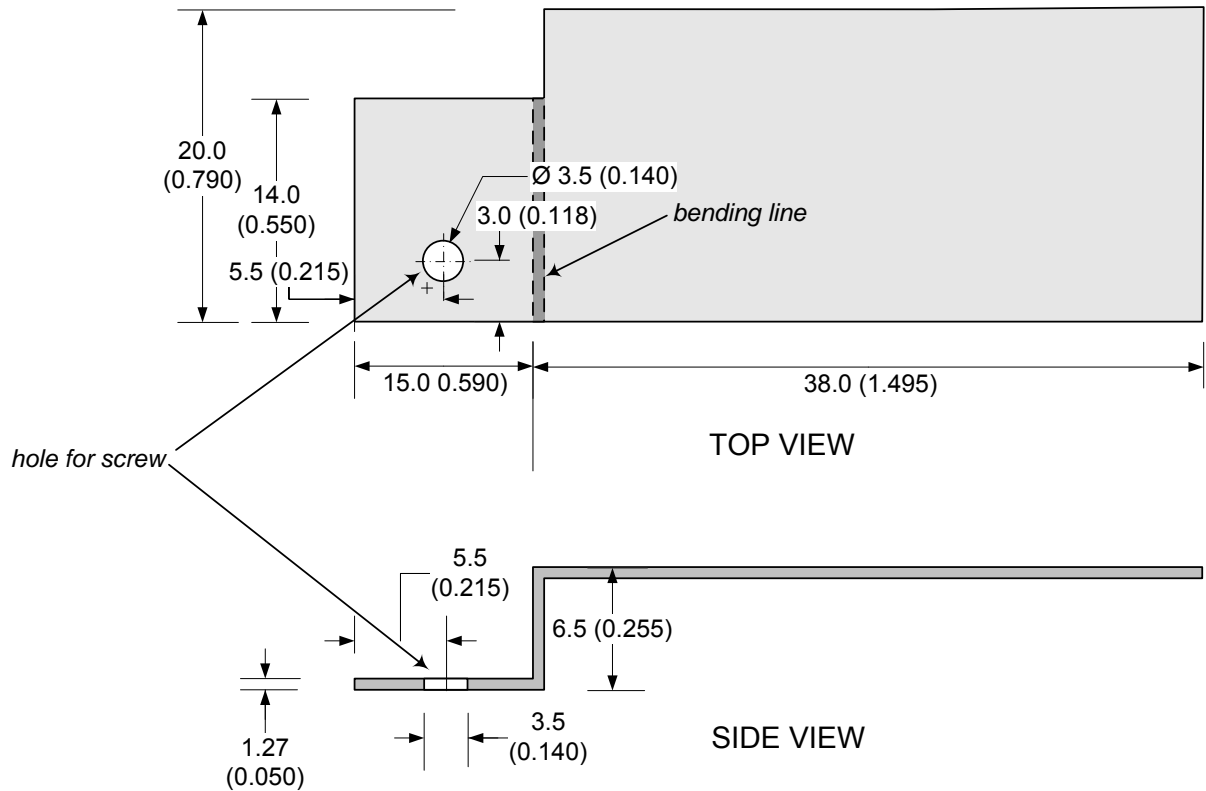


- **Material:** Al, 1100.
- **Thickness:** 0.25mm (0.010")
- **Unit measurement:** mm (inch)
- **Tolerance:** +/- 0.2mm (0.010")
- **Note:** Do not scale the drawing

Figure 18 – Aluminum Heat-Spreader - Auxilliary.



### 9.3 Output Rectifier Heatsink



Material: Al 3003 26 ga  
Thickness: 1.27mm (0.050")

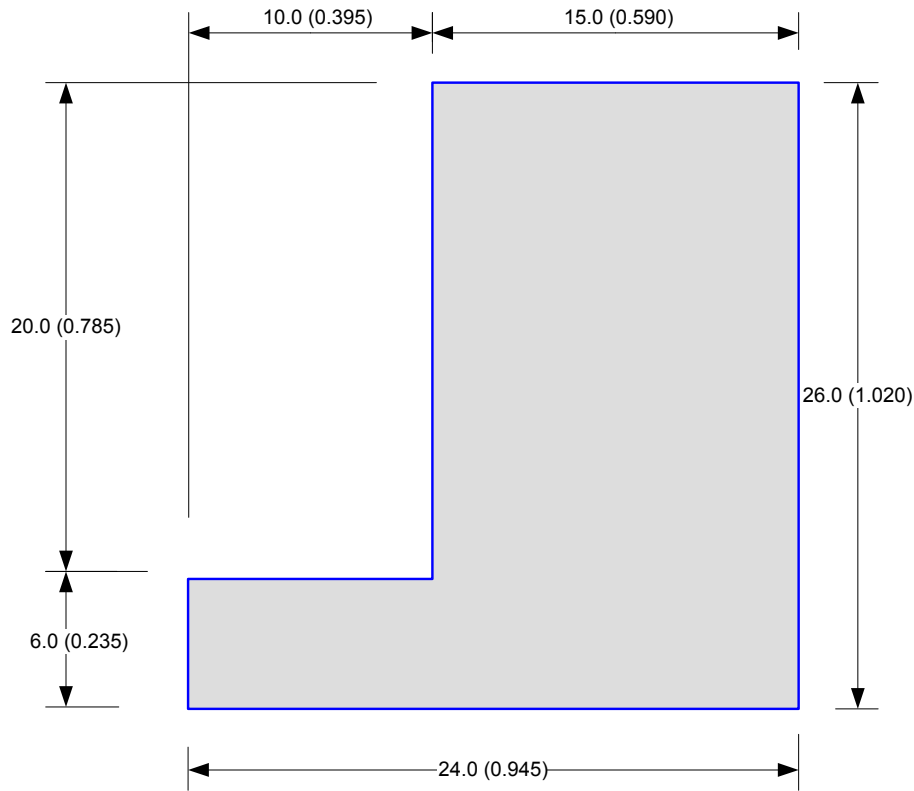
Note:

- Tolerance: +/- 0.2mm(0.010)
- measurement units in: **mm(inch)**
- do not scale drawing

**Figure 19** – Output Rectifier (D27) Aluminum Heatsink.



### 9.4 Bridge Rectifier Heatsink

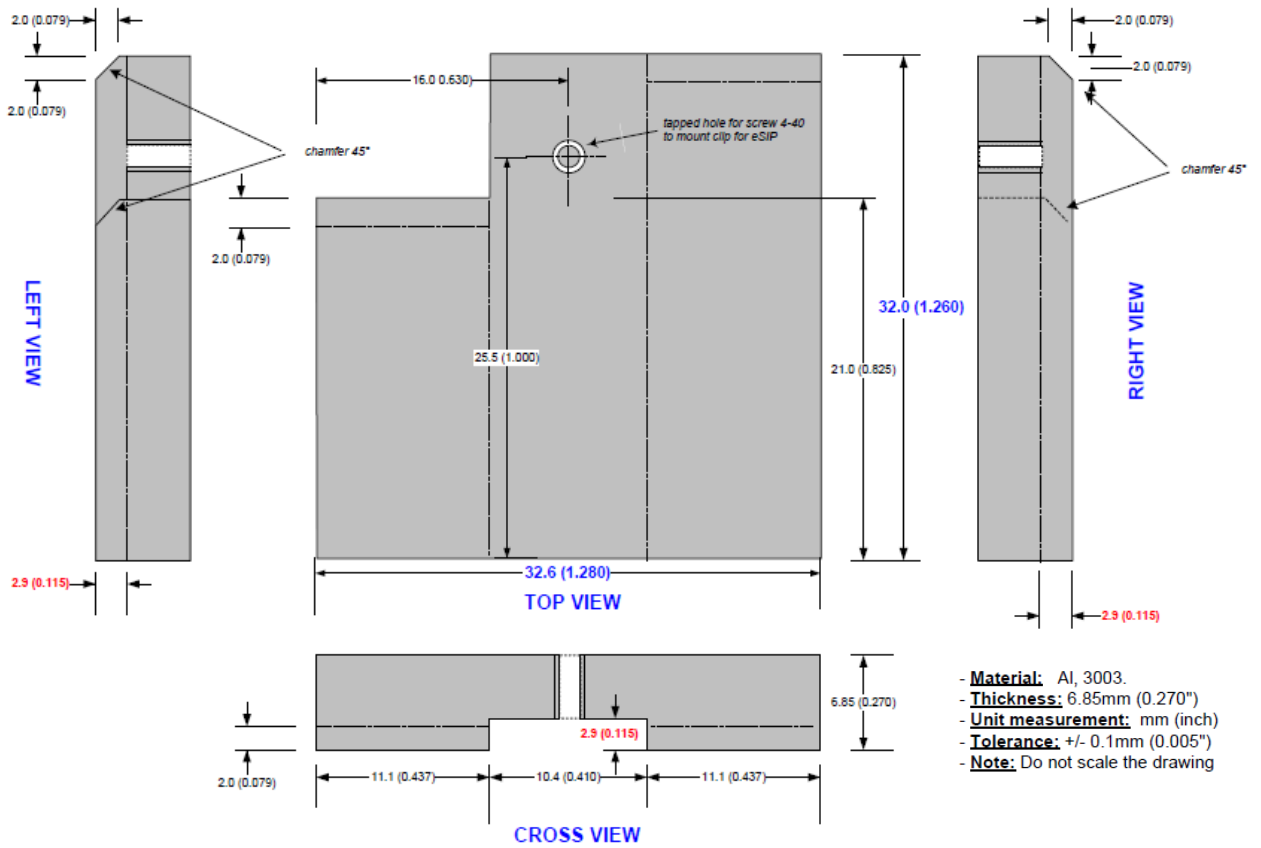


**Figure 20** – Bridge Rectifier (D25) Heatsink.

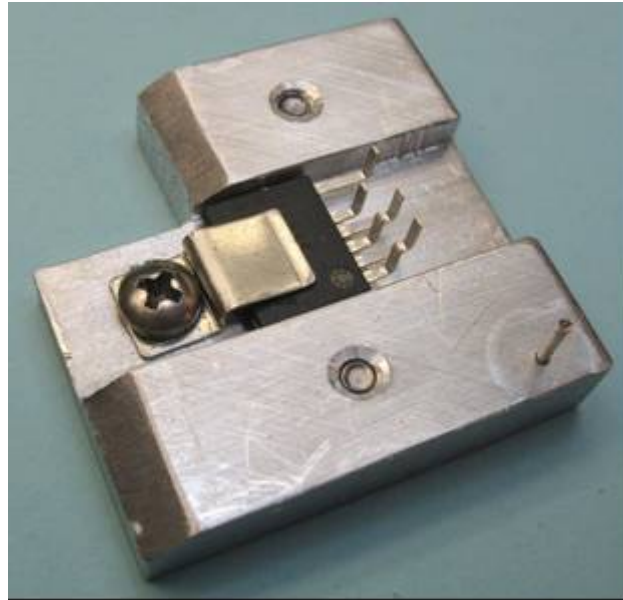


**9.5 TOP259LN Heatsink**

To assemble U11 with a heatsink, the IC package was attached to the custom heatsink using thermal grease and heatsink clip. The sub-assembly consisting of the heatsink and U11 was inserted in place on the PCB. The use of thermally conductive grease removes stress from U11 and heatsink clip provides mechanically reliable contact between U11 and the heatsink.

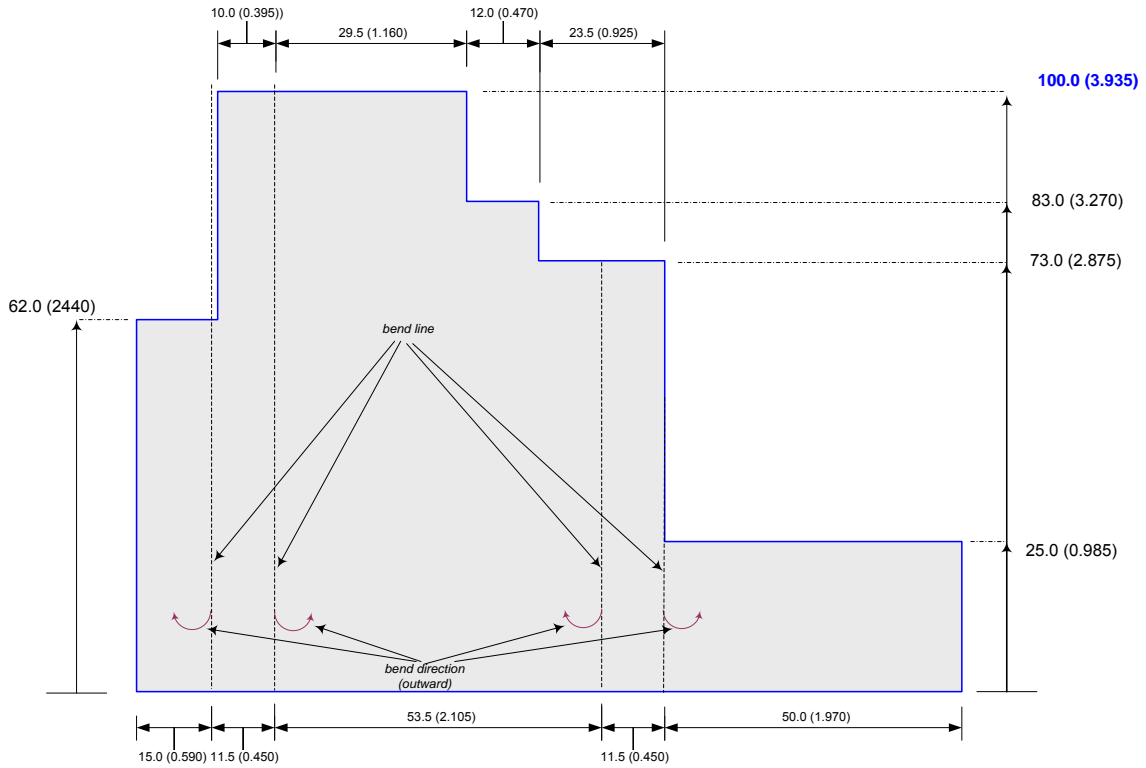


**Figure 21 – eSIP Heatsink (U11).**



**Figure 22** – Photograph of U11 Mounted to Heatsink.  
(Surface Visible to Viewer Makes Contact with PCB when Assembled.)

9.6 Insulator



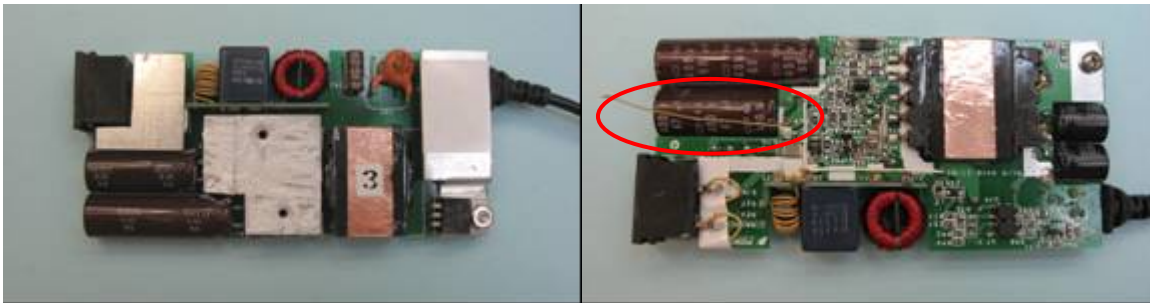
- **Material:** Polypropylene, (PI#: 61-00023-00),
- **Thickness:** 0.25mm (0.010")
- **Unit measurement:** mm (inch)
- **Tolerance:** +/- 0.2mm (0.010")
- **Note:** Do not scale the drawing

Figure 23 – Insulator.



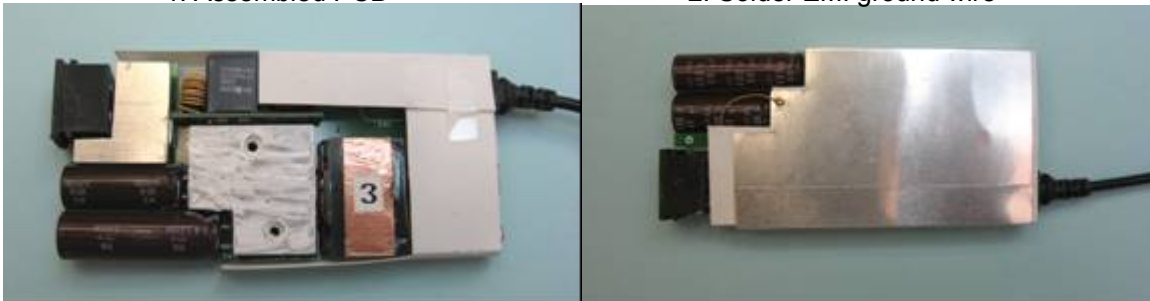


## 10 Assembly of Unit



1. Assembled PCB

2. Solder EMI ground wire



3. Add Insulator

4. Solder EMI ground wire to heatspreader

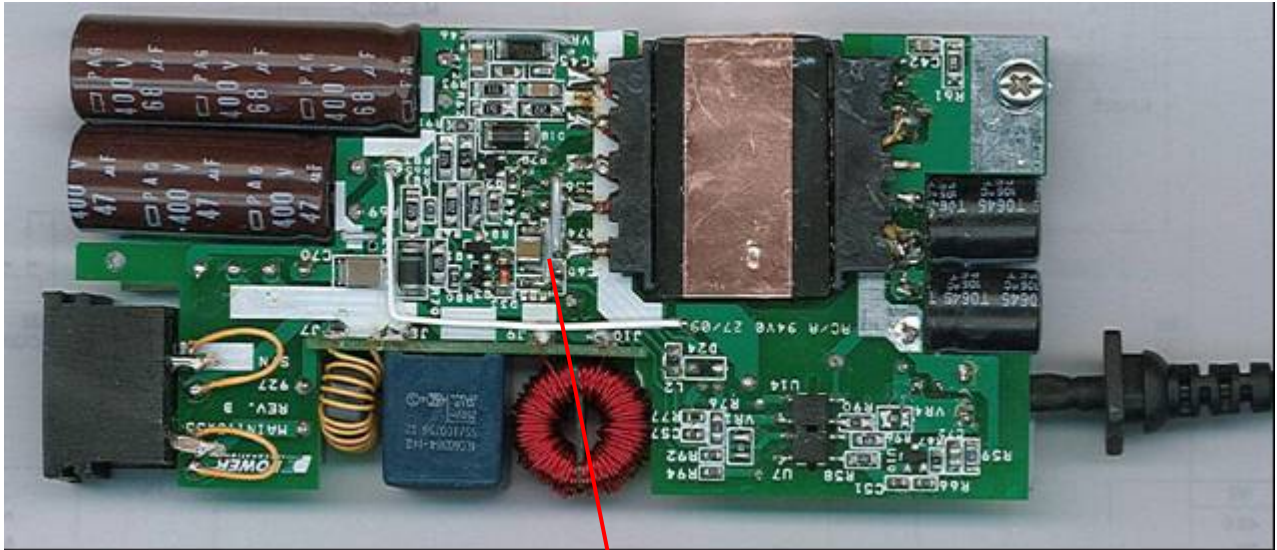


5. Add 0.25 mm Al Heatspreader

6. Ground Heatspreader and Place in Case

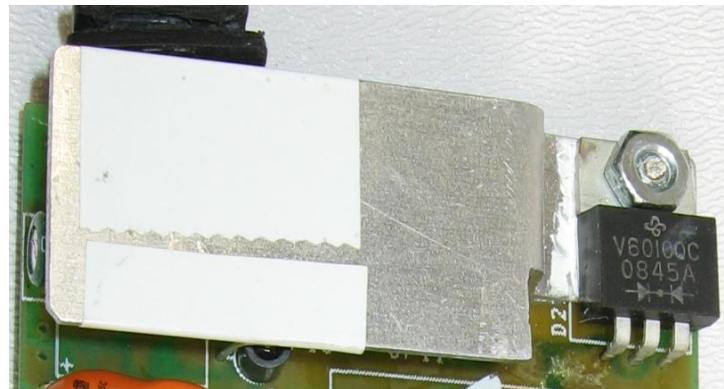


Special Assembly Note (Reworked Rev. A PCB)



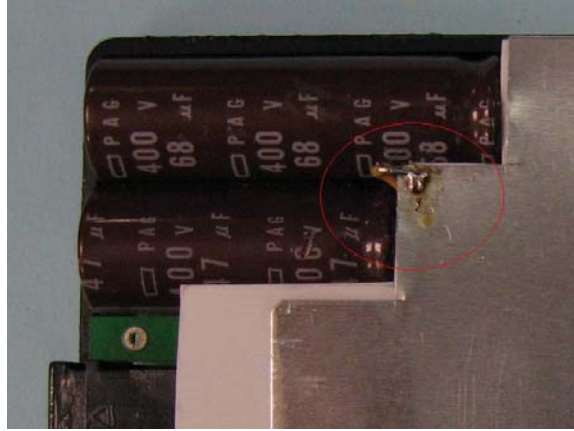
Place jumper between R74,  
R85, and C60 to C56,

**Figure 24** – PCB Bottom View.  
(Guide for Placing the Jumper Wires.)



**Figure 25** – Wrap Diode Heatsink with Tape.





**Figure 26** – #26 AWG-TIW Terminated to Heatspreader.



## 11 Power Supply Performance

All tests were performed at room temperature with 90 V / 50 Hz, 115 V / 60 Hz, 230 V / 50 Hz, and 265 V / 50 Hz line-input voltages and corresponding frequencies unless otherwise noted. The power supply was put in a plastic case (120 mm x 60 mm x 15.4 mm, and allowed to warm up for 30 minutes at full load. The input was provided via a 1 meter AC cable (#18 AWG). The output was measured at the end of a 2 meter cable (#18 AWG), with an impedance of 105 mΩ.

### 11.1 Full Load Efficiency

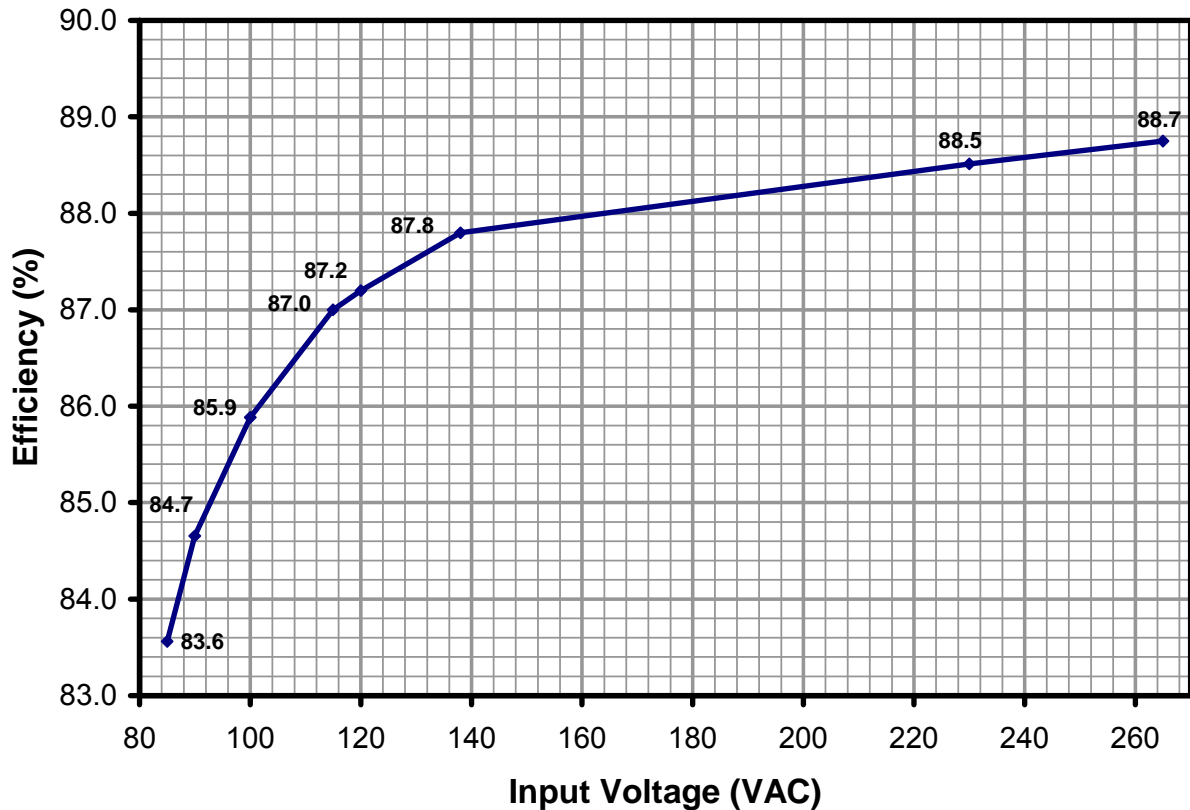


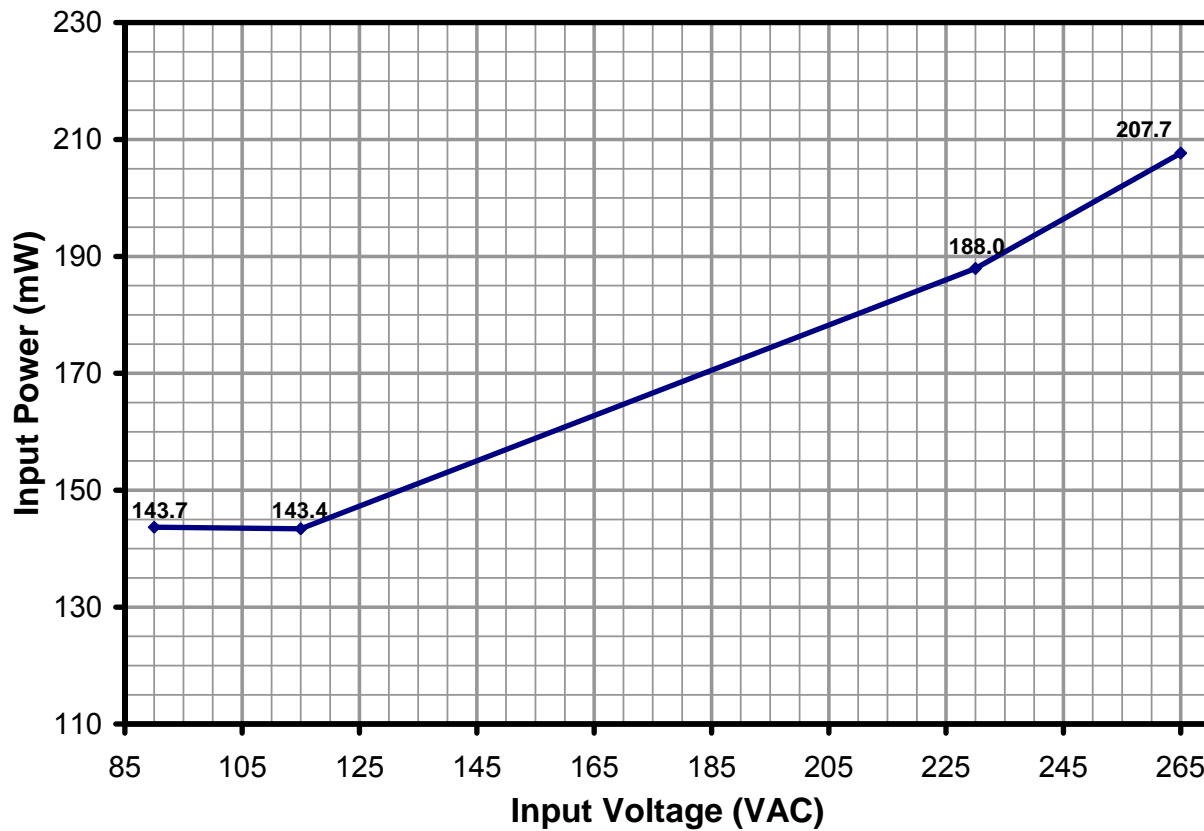
Figure 27 – Efficiency vs Line Voltage at 65 W Load.

Input (VAC / Hz)	V <sub>OUT</sub> (V)	I <sub>OUT</sub> (A)	P <sub>IN</sub> (W)	Efficiency (%)	
85	47	19.44	3.3	77.47	83.56
90	50	19.45	3.3	76.51	84.65
100	50	19.47	3.3	75.49	85.89
115	60	19.49	3.3	74.60	87.00
120	60	19.49	3.3	74.43	87.20
138	63	19.50	3.3	73.96	87.80
230	50	19.51	3.3	73.40	88.51
265	50	19.49	3.3	73.13	88.75

Table 1 – Data for Figure 27.



**11.2 No-load Input Power**



**Figure 28** – No Load Power Consumption.

Freq (Hz)	Input (VAC)	P <sub>IN</sub> (mW)
50	90	143.7
60	115	143.4
50	230	188.0
50	265	207.7

**Table 2** – Data for Figure 28.



### 11.3 Active Mode CEC Measurement Data

All single output adapters, including those provided with products, for sale in California after January 1, 2007 must meet the California Energy Commission (CEC) requirement for minimum active-mode efficiency and no-load input power. Minimum active-mode efficiency is the average efficiency of 25%, 50%, 75%, and 100% of the rated output power, with the limit based on the nameplate output power:

Nameplate Output Power ( $P_o$ )	Minimum Active-mode Efficiency
< 1 W	$0.49 \times P_o$
$\geq 1$ W to $\leq 49$ W	$0.09 \times \ln(P_o) + 0.49$ [ln = natural log]
> 49 W	0.85 W

For single-input adapters the measurement is taken at the rated single nominal input voltage (115 VAC or 230 VAC), for universal input adapters the measurement is made at both nominal input voltages (115 VAC and 230 VAC).

To meet the standard the measured average efficiency (or efficiencies for universal input supplies) must be greater than or equal to the efficiency specified by the CEC/Energy Star standard.

Percent of Full Load (%)	Efficiency (%)	
	115 VAC	230 VAC
25	89.54	89.05
50	88.87	89.31
75	87.91	89.11
100	86.99	88.51
Average	88.33	89.00
CEC specified minimum average efficiency	85	
Energy Star 2.0	87	

**Table 3** – Average Efficiency Data.

More states within the USA, and other countries, are adopting this standard. For the latest up-to-date information visit the Power Integrations Green Room:

<http://www.powerint.com/greenroom/regulations.htm>



11.3.1 Active Mode Efficiency

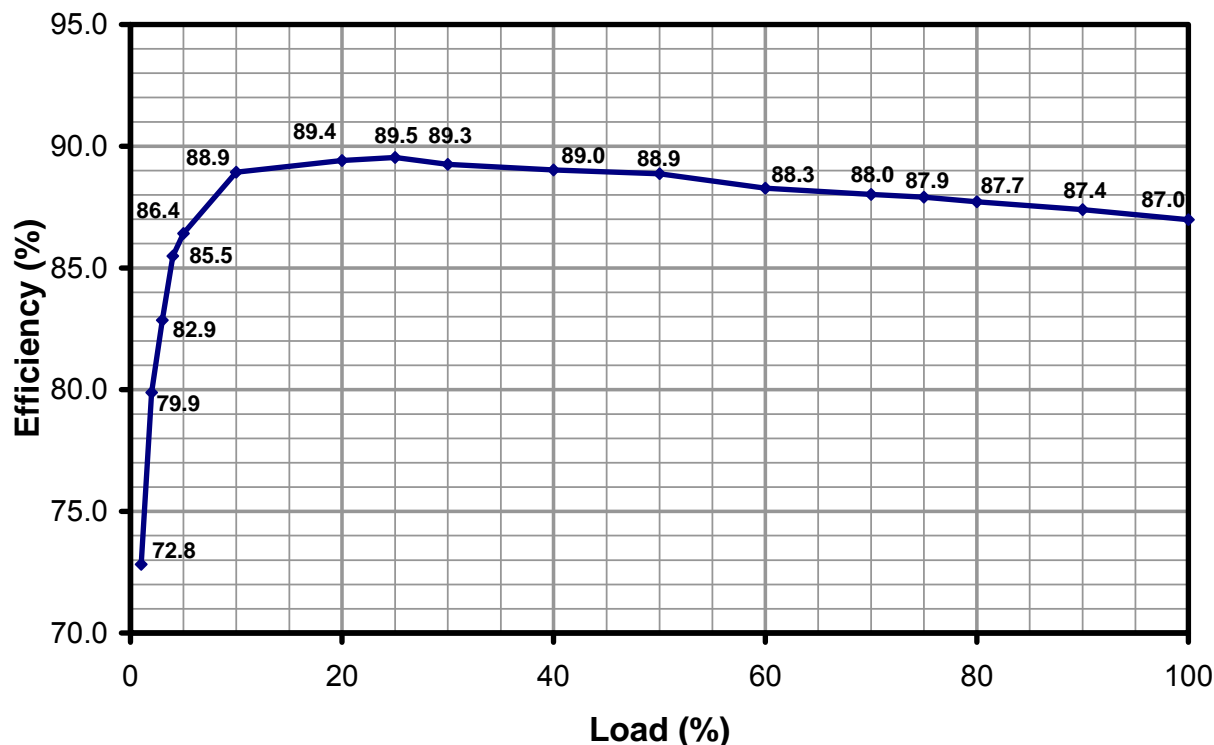


Figure 29 – Efficiency vs. Output Load, Room Temperature (115 VAC, 60 Hz).

Measured end of #18 AWG 2 meter cable; UUT in the plastic case					
115 VAC / 60Hz		Verified after 30 minutes soak time at 25 °C			
Load (%)	I <sub>OUT</sub> (A)	V <sub>OUT</sub> (V)	P <sub>OUT</sub> (W)	P <sub>IN</sub> (W)	Efficiency (%)
1	0.03	19.97	0.66	0.91	72.82
2	0.07	19.97	1.32	1.65	79.88
3	0.10	19.96	1.98	2.39	82.85
4	0.13	19.96	2.63	3.08	85.49
5	0.17	19.95	3.29	3.81	86.42
10	0.33	19.89	6.56	7.38	88.94
20	0.66	19.82	13.08	14.63	89.41
25	0.83	19.84	16.37	18.28	89.54
30	0.99	19.69	19.49	21.84	89.25
40	1.32	19.70	26.00	29.21	89.02
50	1.65	19.67	32.46	36.52	88.87
60	1.98	19.67	38.95	44.12	88.27
70	2.31	19.62	45.32	51.49	88.02
75	2.48	19.60	48.51	55.18	87.91
80	2.64	19.57	51.66	58.90	87.72
90	2.97	19.53	58.00	66.37	87.40
100	3.30	19.48	64.28	73.90	86.99
<b>Average Efficiency</b>					<b>88.33%</b>

Table 4 – Data for Figure 29.





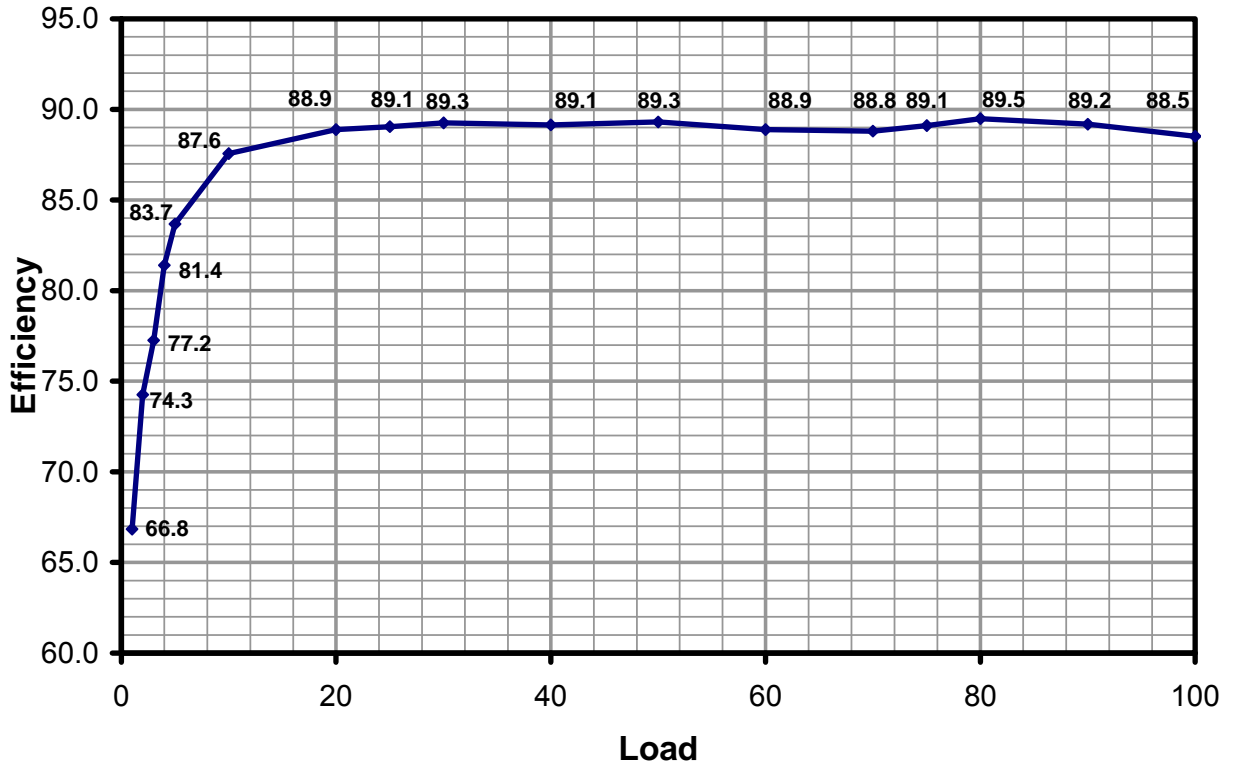


Figure 30 – Efficiency vs. Output Load, Room Temperature (230 VAC, 50 Hz).

Measured end of #18 AWG 2 meter cable; UUT in plastic area					
230 VAC / 50Hz			Verified after 30 minutes soak time at 25 °C		
Load (%)	I <sub>OUT</sub> (A)	V <sub>OUT</sub> (V)	P <sub>OUT</sub> (W)	P <sub>IN</sub> (W)	Efficiency (%)
1	0.03	19.97	0.66	0.99	66.84
2	0.07	19.97	1.32	1.78	74.25
3	0.10	19.96	1.98	2.56	77.25
4	0.13	19.95	2.63	3.24	81.40
5	0.17	19.95	3.29	3.93	83.67
10	0.33	19.90	6.57	7.50	87.56
20	0.66	19.81	13.07	14.71	88.88
25	0.83	19.84	16.37	18.38	89.05
30	0.99	19.70	19.50	21.85	89.26
40	1.32	19.72	26.03	29.20	89.15
50	1.65	19.67	32.46	36.34	89.31
60	1.98	19.64	38.89	43.75	88.89
70	2.31	19.61	45.30	51.01	88.80
75	2.48	19.59	48.49	54.41	89.11
80	2.64	19.57	51.66	57.73	89.49
90	2.97	19.53	58.00	65.04	89.18
100	3.30	19.50	64.35	72.70	88.51
<b>Average Efficiency</b>					<b>89.00</b>

Table 5 – Data for Figure 30.





### 11.4 Available Standby Output Power

The chart below shows the available output power vs. line voltage, with input power levels of 1 W, 1.5 W, and 2.4 W.

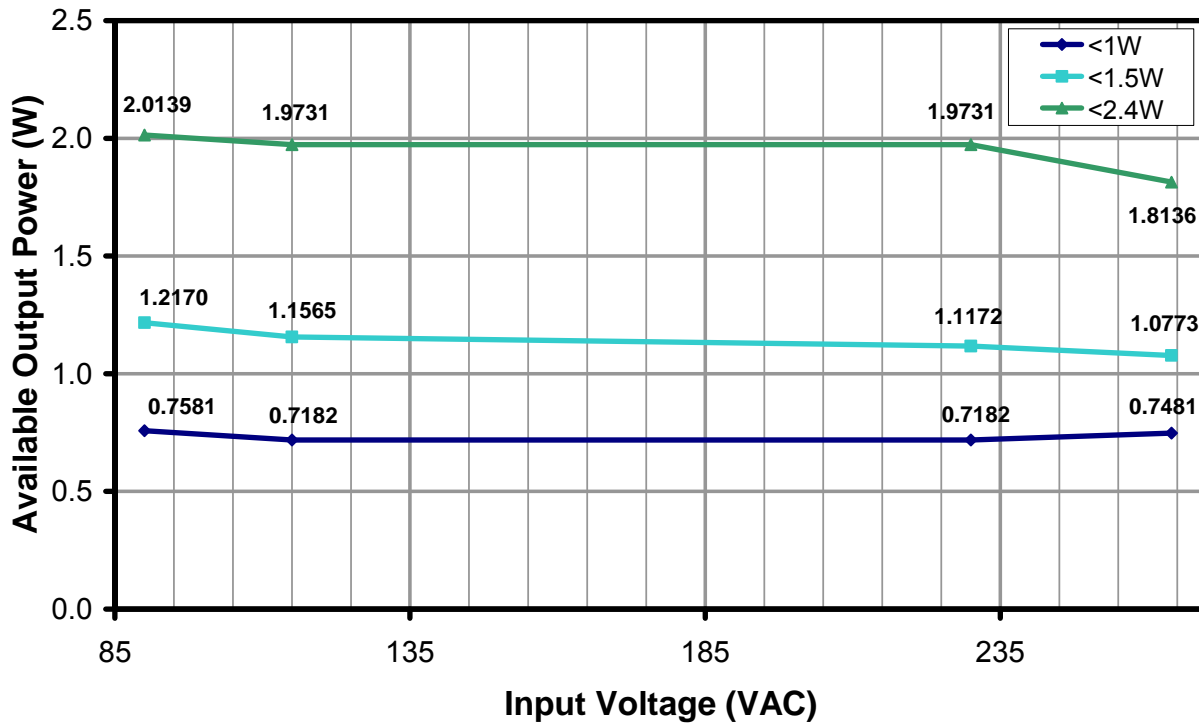


Figure 31 – Output Power Corresponding to Varying Input Power.



### 11.5 Line and Load Regulation

All data was measured at the end of the output cable.

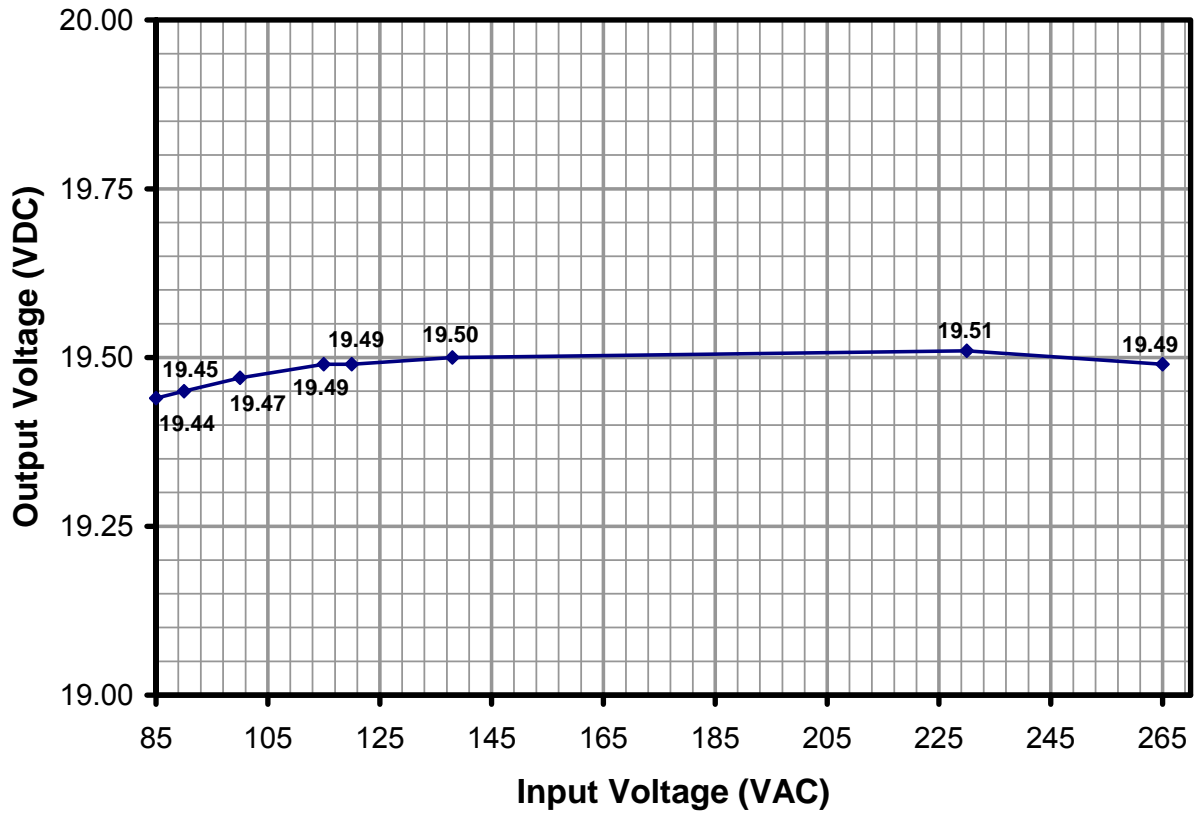


Figure 32 – Output Voltage vs. Line Voltage, with 3.3 A Load, Room Temperature.



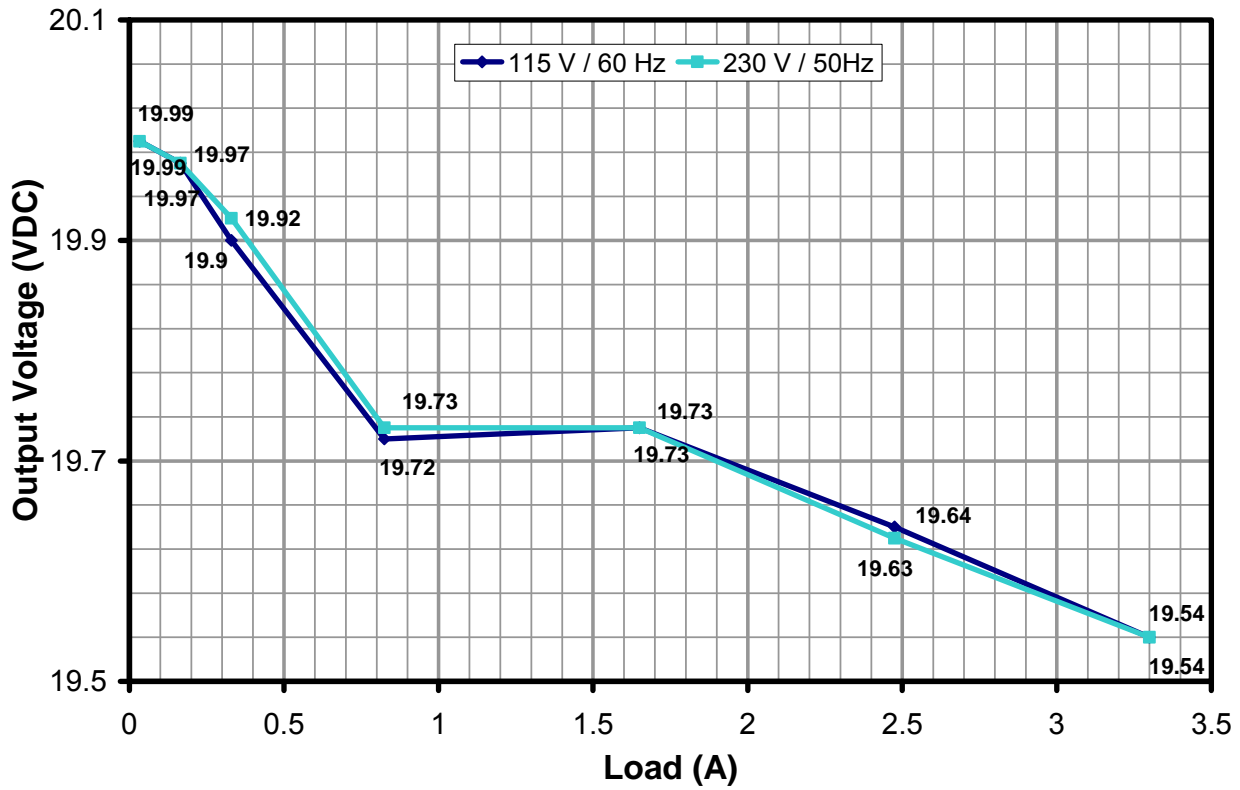


Figure 33 – Load Regulation, Room Temperature (Dominated by Cable Drop).



## 12 Thermal Performance

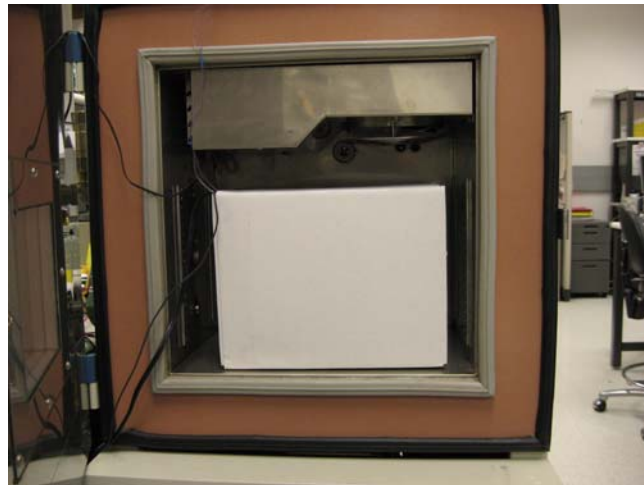
The power supply was placed inside a custom Power Integrations plastic case and sealed, without potting material. The supply was heated, with no airflow, for at least two hours and measurements were taken immediately.

For reliability testing, the power supply went through a burn-in cycle, which involved running it inside an oven overnight in a 40 °C ambient temperature condition at maximum load. The unit did not at any time go into thermal shutdown.

Load conditions: 65 W at the end of a 2 meter, #18 AWG cable (105 mΩ).



**Figure 34** – Power Supply Adapter Inside Carton Box and on Top of Bakelite Board for Burn-In Test.



**Figure 35** – Carton box, with Power Supply Adapter Inside, Placed in Oven for Burn-in.

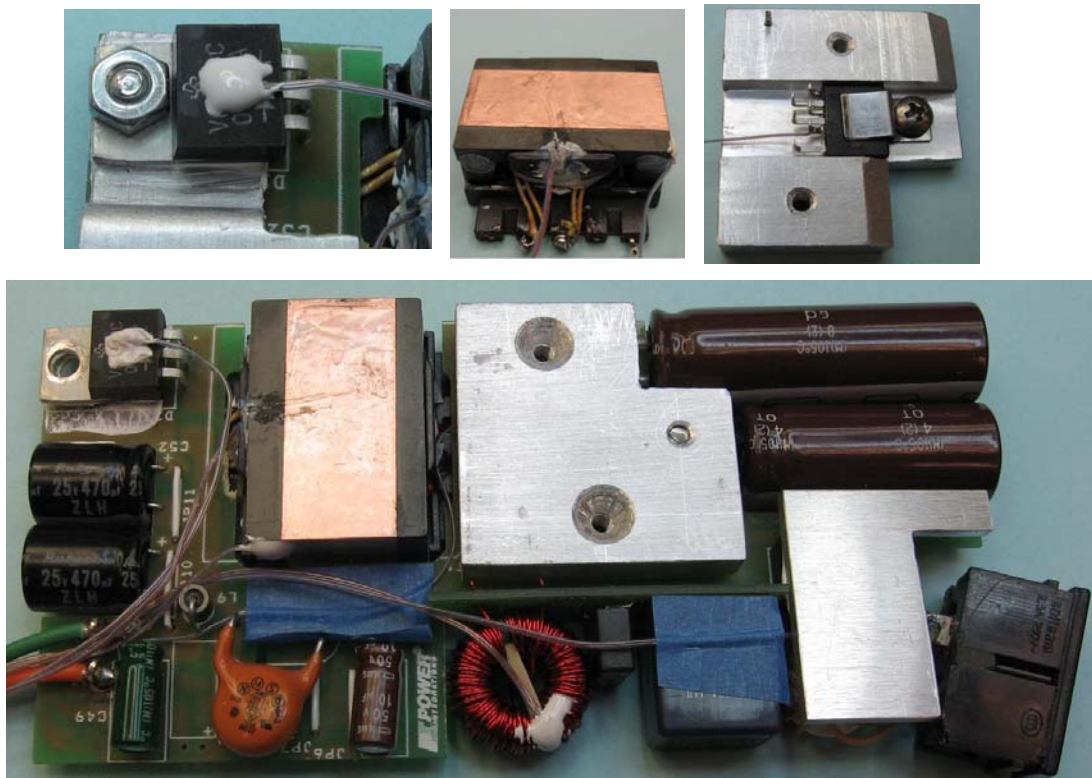


Figure 36 – Thermocouple Locations.

### 12.1 Chamber Temperature Data

Item	Temperature (°C)	
	90 VAC / 50 Hz Input	265 VAC / 50 Hz Input
Ambient Temperature in the Box	40	40
U11(at Source)	98.5	90.2
D25 (Case of Bridge)	97.4	79.3
T1 (Core / Winding)	94.9	92.1
D27 (Case of Output Rec)	92.1	90.7
Measured Input Power (W)	76.21	73.73
Output Voltage (V)	19.55	19.63
Output Load (A)	3.333	3.33

Table 6 – Thermal Data.

## 12.2 Case Surface Temperature (IR Thermal Image)

Condition: Unit was running for two hours inside the plastic case as shown when the measurement was taken. The output was continuous at 3.33 A at 90 VAC / 50Hz.

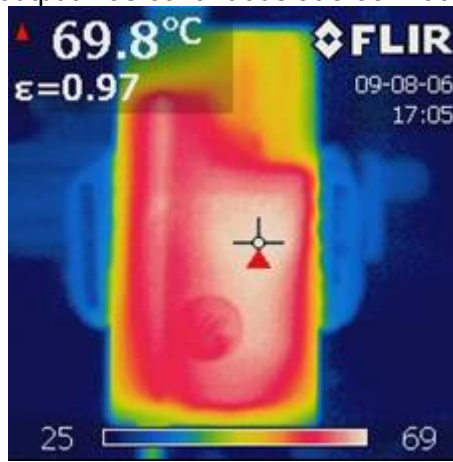


Figure 37 – Top of Case

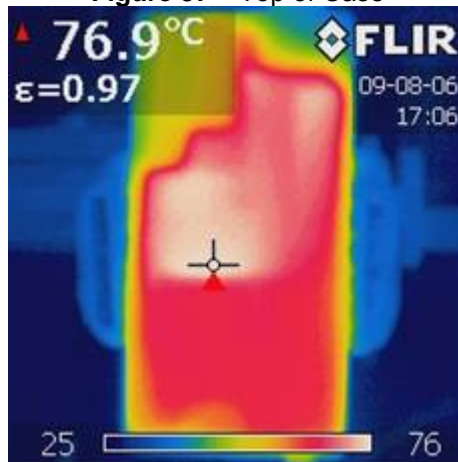


Figure 38 – Bottom of the Case

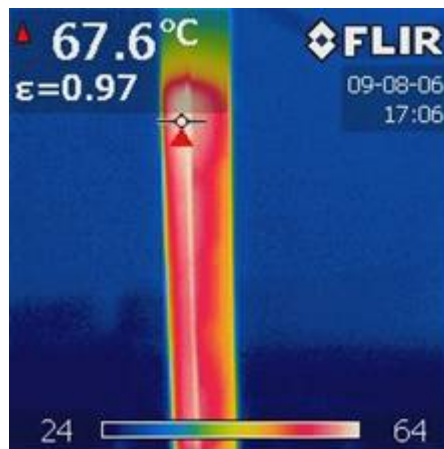


Figure 39 – Hottest Side of the Case.

**11.2 Case Surface Temperature (Thermocouple Wire)**

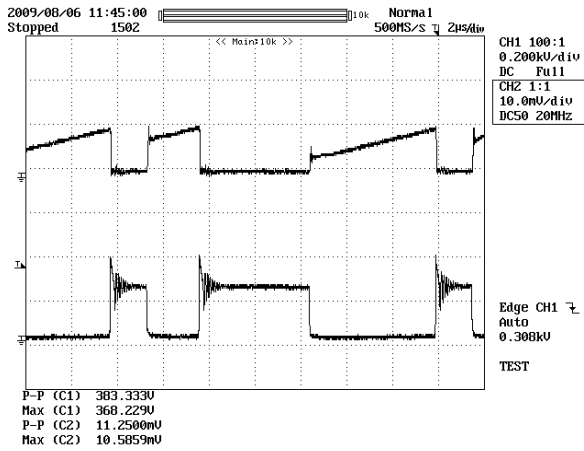


**Figure 40** – Unit Placed on a Bakelite Board and Inside a Customer Specified Plastic-glass Chamber. Ambient Temperature: 28.8 °C; Case Temperature (Top): 74.3 °C; TOPSwitch Temperature: 97.2 °C.

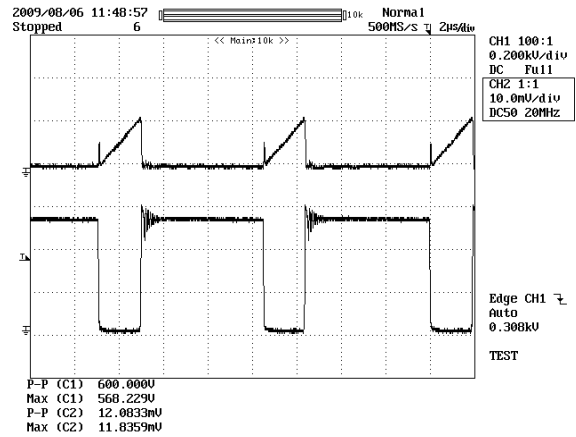


### 13 Waveforms

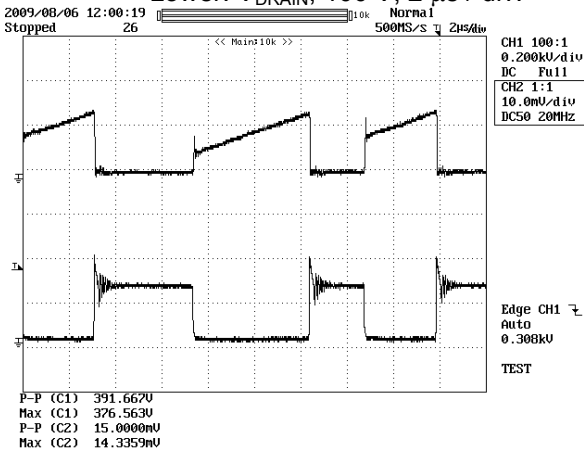
#### 13.1.1 Drain Voltage and Current



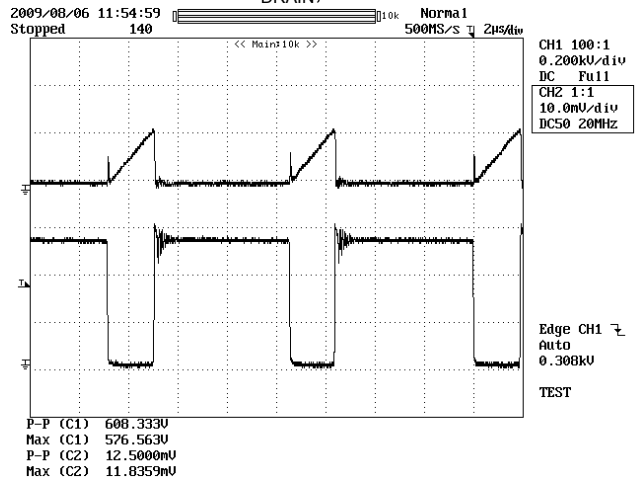
**Figure 41** – 90 VAC, 47Hz, Overload Condition – 4 A Output. Without OCP Protection. Upper:  $I_{DRAIN}$ , 2 A / div. Lower:  $V_{DRAIN}$ , 100 V, 2  $\mu$ s / div.



**Figure 42** – 265 VAC, Overload Condition – 4 A Output. Without OCP Protection. Upper:  $I_{DRAIN}$ , 2 A / div. Lower:  $V_{DRAIN}$ , 200 V / div.



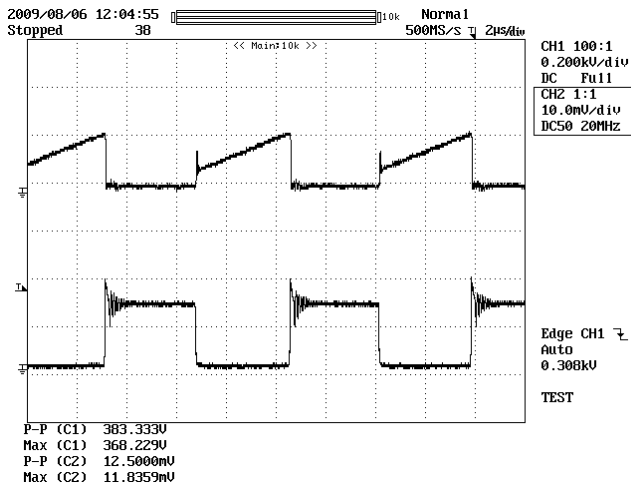
**Figure 43** – 90 VAC, Overload Condition – 4 A Output. With OCP Protection. Upper:  $I_{DRAIN}$ , 2 A / div. Lower:  $V_{DRAIN}$ , 100 V, 2  $\mu$ s / div.



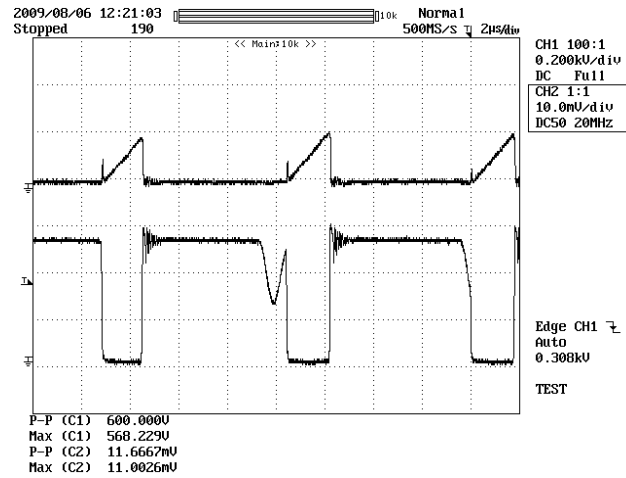
**Figure 44** – 265 VAC, Overload Condition – 4 A Output. With OCP Protection. Upper:  $I_{DRAIN}$ , 2 A / div. Lower:  $V_{DRAIN}$ , 200 V / div.





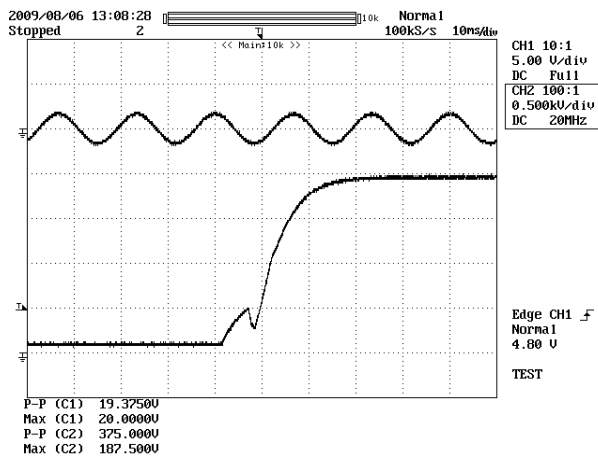


**Figure 45** – 90 VAC, 47Hz Full-load Condition.  
Upper:  $I_{DRAIN}$ , 2 A / div.  
Lower:  $V_{DRAIN}$ , 100 V, 2  $\mu$ s / div.

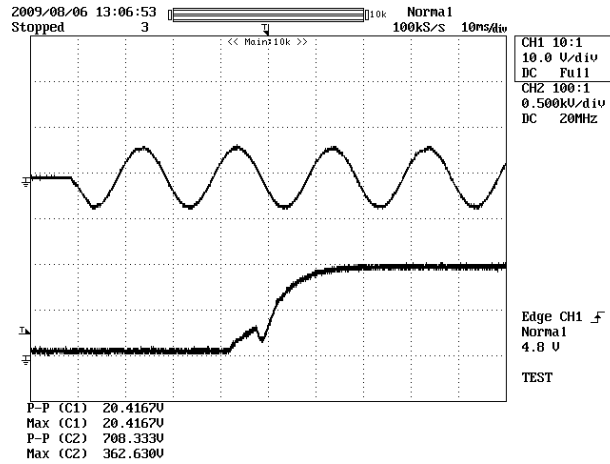


**Figure 46** – 265 VAC, Full-load Condition.  
Upper:  $I_{DRAIN}$ , 2 A / div.  
Lower:  $V_{DRAIN}$ , 200 V / div.

### 13.2 Output Voltage Start-up Profile



**Figure 47** – Start-up Profile, 115 VAC  
5 V, 50 ms / div.

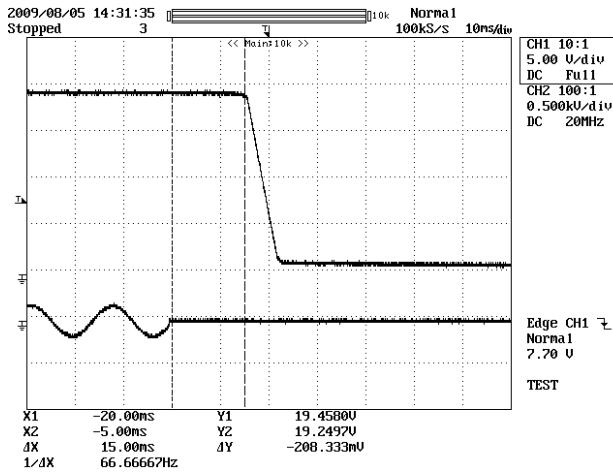


**Figure 48** – Start-up Profile, 230 VAC  
5 V, 50 ms / div.

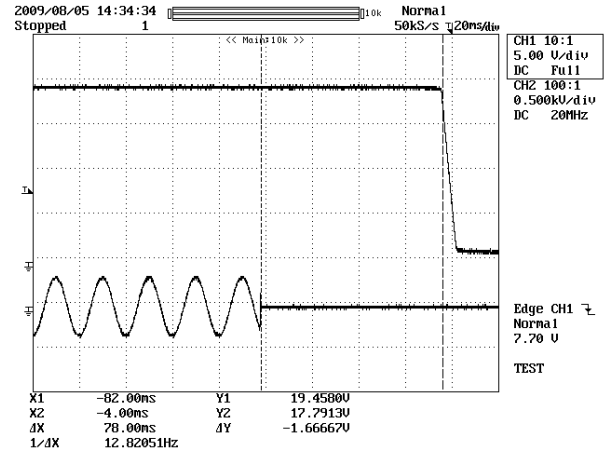
Note: Dip in output voltage is due to the electronic load and does not exist with resistive loading.



### 13.3 Hold-up Time



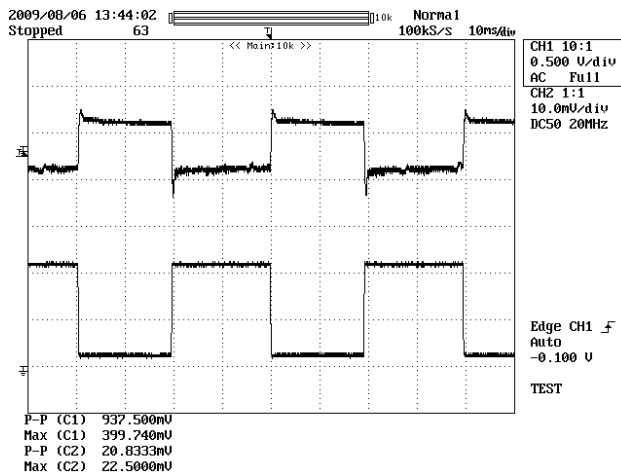
**Figure 49** – Hold Time; Full Load.  
115 VAC / 60 Hz; 10 ms / div.  
Lower:  $V_{IN}$ , 500 V / div.  
Upper:  $V_{OUT}$ , 5 V / div.



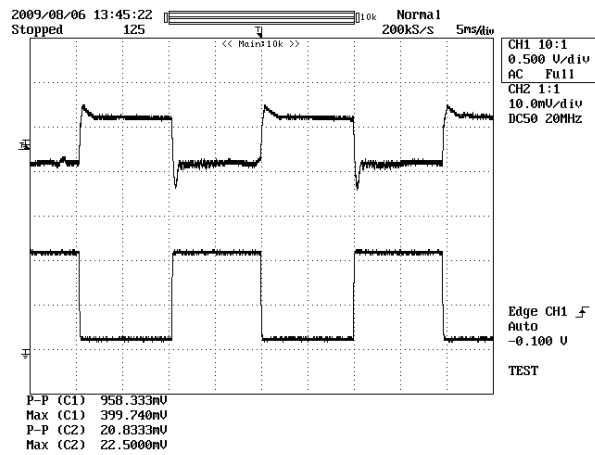
**Figure 50** – Hold Time; Full Load.  
230 VAC / 50 Hz; 10 ms / div.  
Lower:  $V_{IN}$ , 500 V / div.  
Upper:  $V_{OUT}$ , 5 V / div.

### 14 Load Transient Response

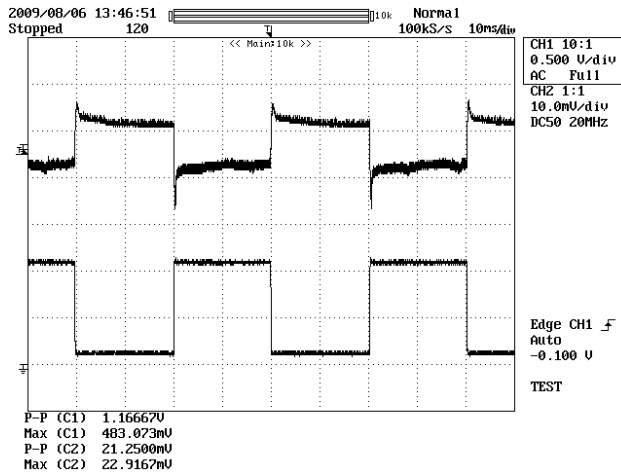
In the figures below, signal averaging was used to better enable viewing the load transient response. The oscilloscope was triggered using the load current step as a trigger source. Since the output switching and line frequency occur essentially at random with respect to the load transient, contributions to the output ripple from these sources average out, leaving only the contribution from the load step response.



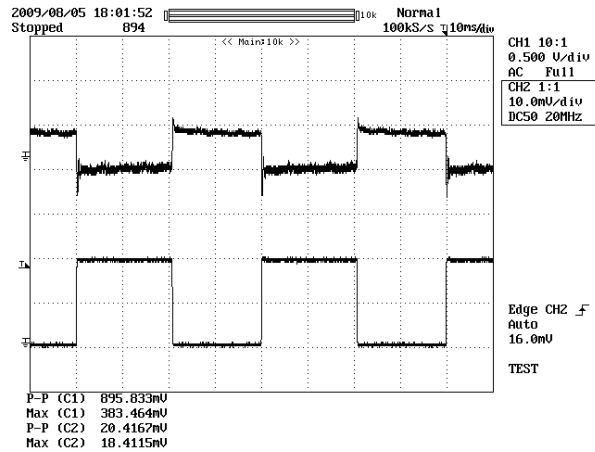
**Figure 51** – 0.3 A - 3.33 A (10 to 100%) Load, 50 Hz; Slew Rate = 0.1 A /  $\mu$ s; Terminated with 180  $\mu$ F Load.  $V_{IN}$ : 90 VAC / 47 Hz. Upper:  $V_{OUT}$ , 1 V / div. Lower:  $I_{OUT}$ , 1 A / div.



**Figure 52** – 0.3 A - 3.33 A (10 to 100%) Load 100 Hz; Slew Rate = 0.1 A /  $\mu$ s; Terminated with 180  $\mu$ F Load.  $V_{IN}$ : 90 VAC / 47 Hz. Upper:  $V_{OUT}$ , 1 V / div. Lower:  $I_{OUT}$ , 1 A / div.



**Figure 53** – 10 to 100% Load; Slew Rate = 0.1 A /  $\mu$ s; Non-capacitive Termination.  $V_{IN}$ : 90 VAC / 47 Hz. Upper:  $V_{OUT}$ , 1 V / div. Lower:  $I_{OUT}$ , 1 A / div.



**Figure 54** – 10 to 100% Load; Slew Rate = 0.1 A /  $\mu$ s; Non-capacitive Termination.  $V_{IN}$ : 264 VAC / 63 Hz. Upper:  $V_{OUT}$ , 1 V / div. Lower:  $I_{OUT}$ , 1 A / div.



### 15 Output Rise Time Profile <20 ms

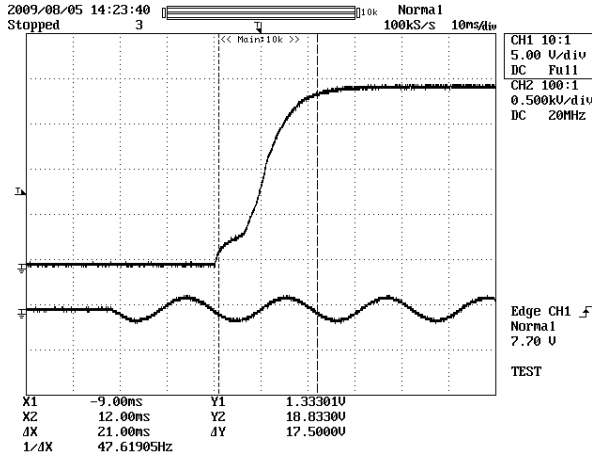


Figure 55 – 90 VAC / 47 Hz; Maximum Load.

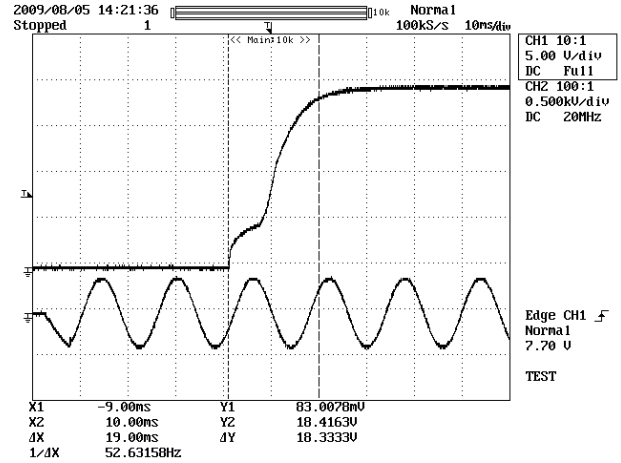


Figure 56 – 265 VAC / 63 Hz; Maximum Load.



## 16 Over Voltage Protection – Latching

To take these measurements, the feedback loop was opened (by breaking it at the optocoupler) to cause a rise in the output voltage and trigger an OV shutdown.

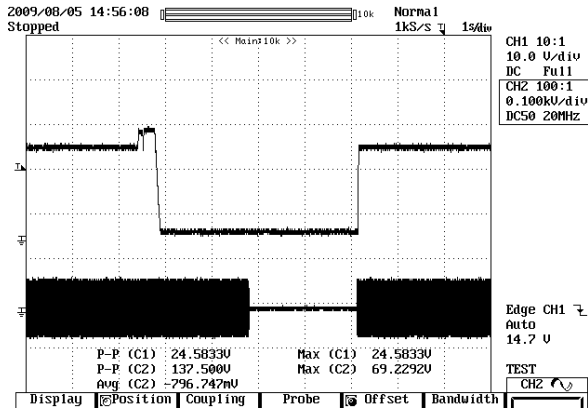


Figure 57 – Output Voltage: 0.1 A Load, 90 VAC; 5 V / div.

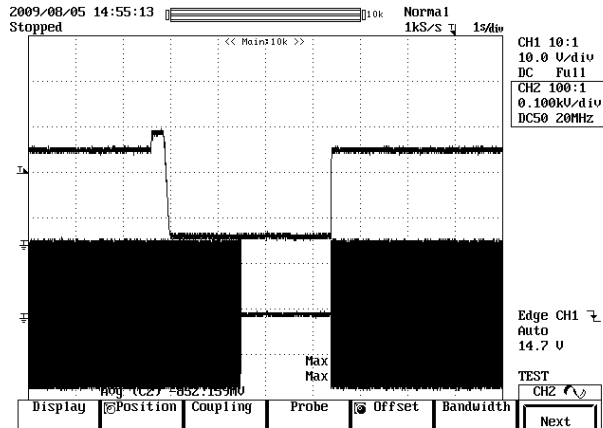


Figure 58 – Output Voltage: 0.1 A Load, 265 VAC; 5 V / div.

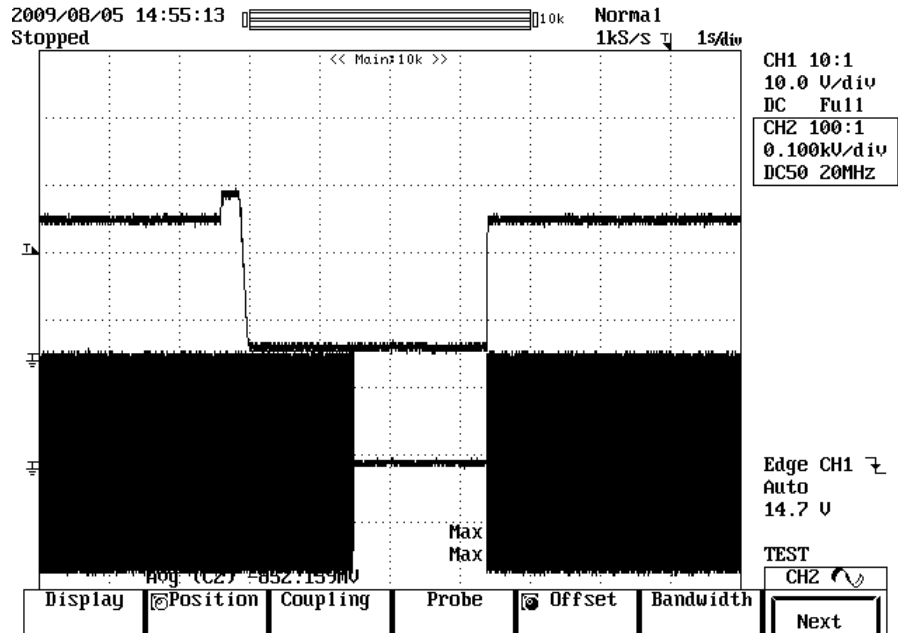
### 16.1 Overload Protection

	VIN (VAC)			
	90 V	115 V	230 V	265 V
Overload current before auto-restart (V <sub>OUT</sub> ~19.68 V)	3.95 A	4.6 A	4.71 A	4.32 A



### 17 AC Reset

This shows operation of the fast AC reset function. An overvoltage was applied and the AC input was cycled to reset the latch.

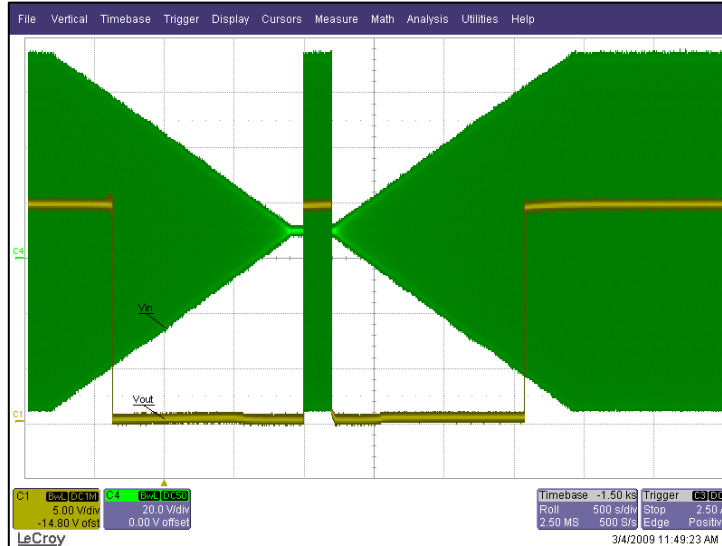


**Figure 59** – AC Reset and Recovery After Overvoltage Latch, 265 VAC.  
 Ch2: Rectified AC Source.  
 Ch3: Output Voltage; 10 V, 500 ms / div.



### 18 Brownout and Recovery

The input voltage decreases from 90 VAC / 50 Hz down to zero in 30 minutes. Then input voltage increases from 0 VAC up to 90 VAC / 50 Hz in 30 minutes. The UUT output should recover.



**Figure 60 – Brownout and Recovery.**  
 Ch1: Output Voltage; 5 V / div.  
 Ch4: AC Input Voltage; 20 V / div , 500 ms / div.



### 19 Line Cycle Dropout

The unit is subjected to a dropout of the AC line voltage from 100 VAC / 50 Hz to zero voltage for duration which equal to 10 ms repeated 10 times with a period of 1 second. The unit is fully loaded. Dropout shall occur at any input phase angle.

Ch2: Output Voltage; 5 V / div.

Ch4: Input Voltage; 100 V / div.

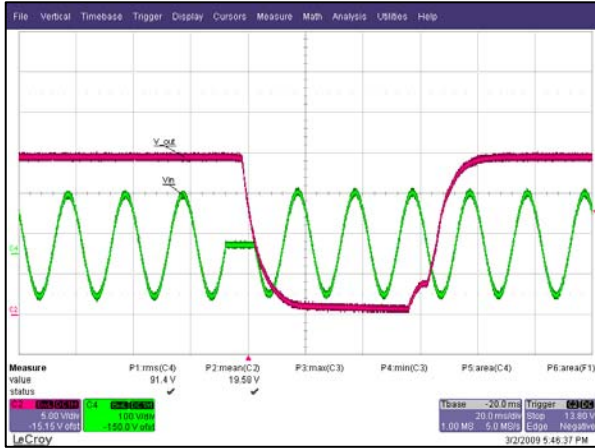


Figure 61 – 90 V / 50 Hz at 0° Dropout.

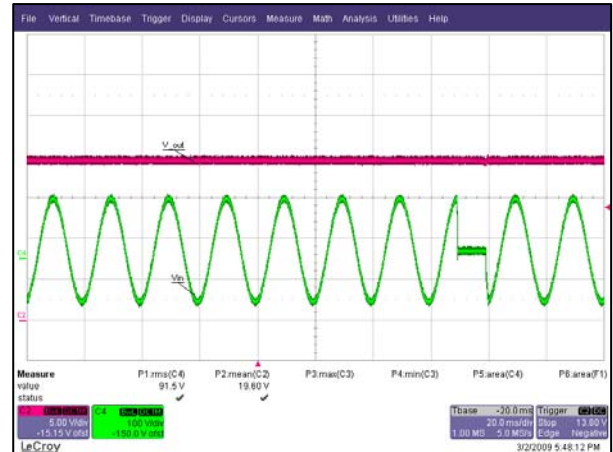


Figure 62 – 80 V / 50 Hz at 90° Dropout.

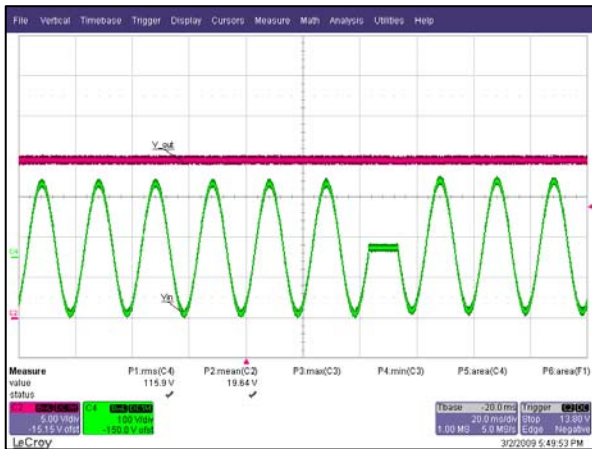


Figure 63 – 100 V / 50 Hz at 0° Dropout.

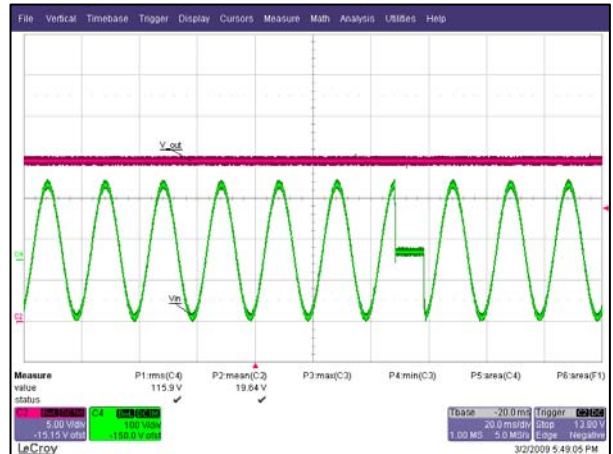


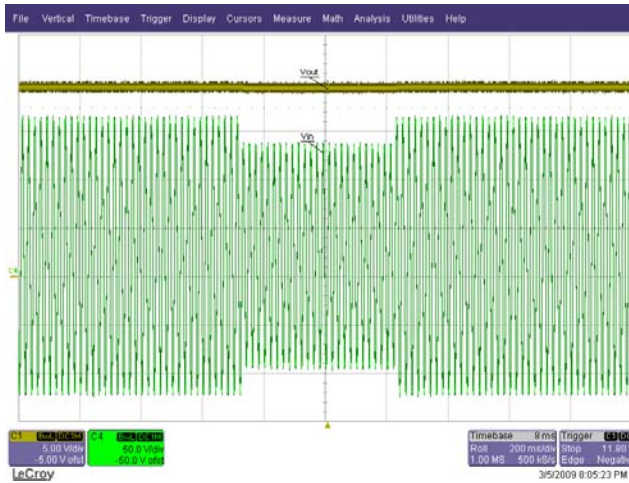
Figure 64 – 100 V / 50 Hz at 90° Dropout.



## 20 Line Sag

While the unit is operating with maximum continuous load, the line voltage is switched to the sag voltage as indicated below:

100 VAC to 80 VAC for 0.5 sec., and back to 100 VAC at 50 Hz, repeated 10 times with 10 seconds interval.



**Figure 65** – Line Sag; Ch1: 5 V / div (V<sub>OUT</sub>); Ch4: 50 V / div (V<sub>IN</sub>).



## 21 Line Swell

While the unit is operating with maximum continuous load, the line voltage is switched to the swell voltage as indicated below:

220 VAC to 286 VAC for 1 sec, and back to 220 VAC at 50 Hz, repeated 10 times with 10 seconds interval.

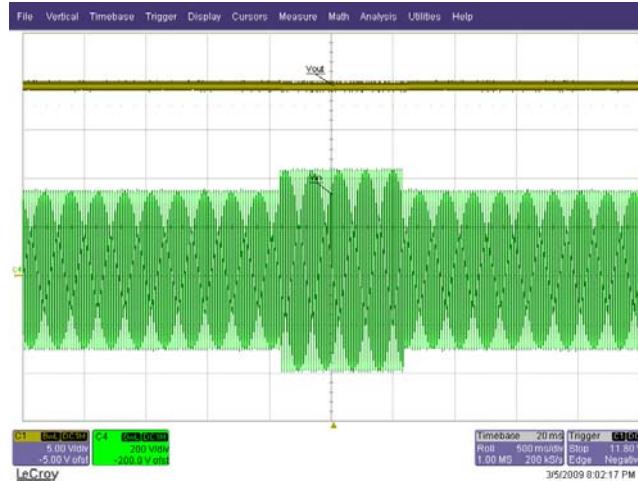


Figure 66 – Line Swell; Ch1: 5 V / div (V<sub>OUT</sub>); Ch4: 200 V / div (V<sub>IN</sub>).

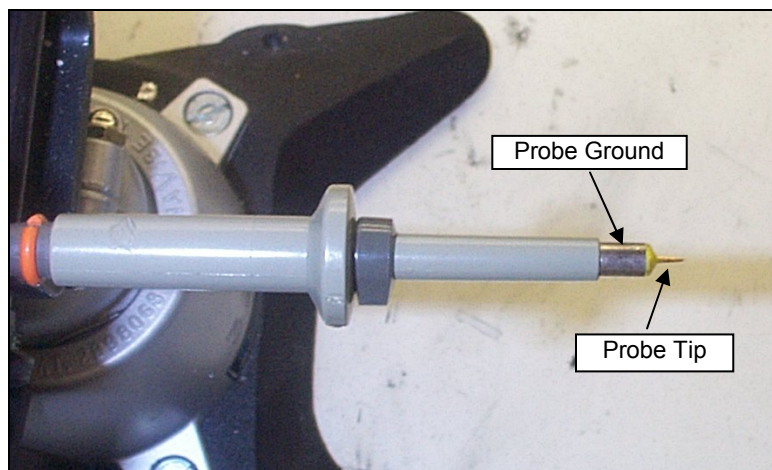


## 22 Output Ripple Measurements

### 22.1 Ripple Measurement Technique

For DC output ripple measurements, use a modified oscilloscope test probe to reduce spurious signals. Details of the probe modification are provided in figures below. The waveforms were captured at the end of the output cord.

Tie two capacitors in parallel across the probe tip of the 4987BA probe adapter. Use a 0.1  $\mu\text{F}/50\text{ V}$  ceramic capacitor and a 1.0  $\mu\text{F}/50\text{ V}$  aluminum-electrolytic capacitor. The aluminum-electrolytic capacitor is polarized, so always maintain proper polarity across DC outputs



**Figure 67** – Oscilloscope Probe Prepared for Ripple Measurement. (End cap and ground lead removed)



**Figure 68** – Oscilloscope Probe with Probe Master 4987BA BNC Adapter. (Modified with wires for probe ground for ripple measurement, and two parallel decoupling capacitors added)

### 22.2 Measurement Results

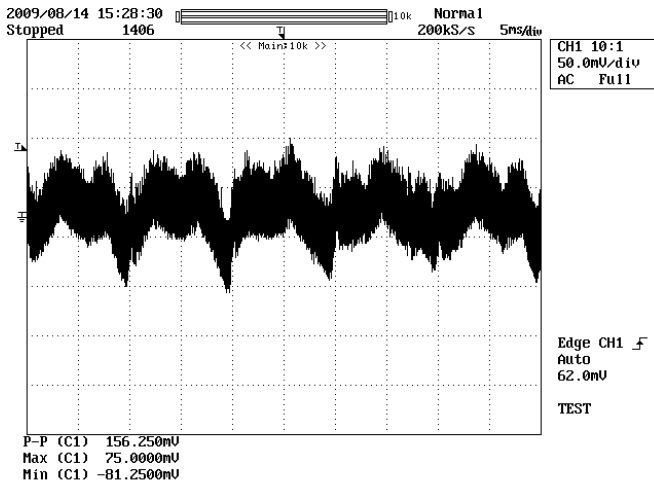


Figure 69 – Ripple, 90 VAC, Full Load.  
500 ms / div, 50 mV / div.

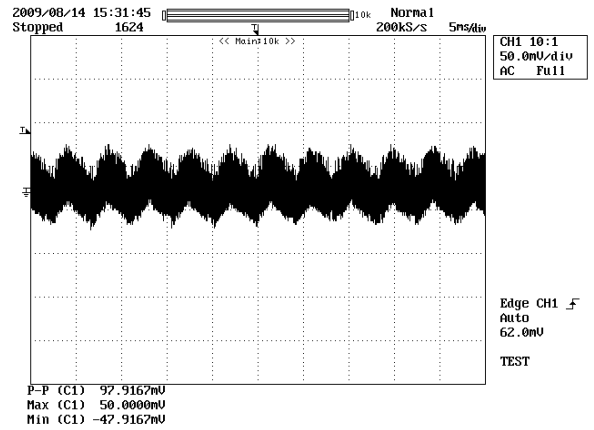


Figure 70 – Ripple, 230 VAC, Full Load.  
500 ms / div, 50 mV / div.

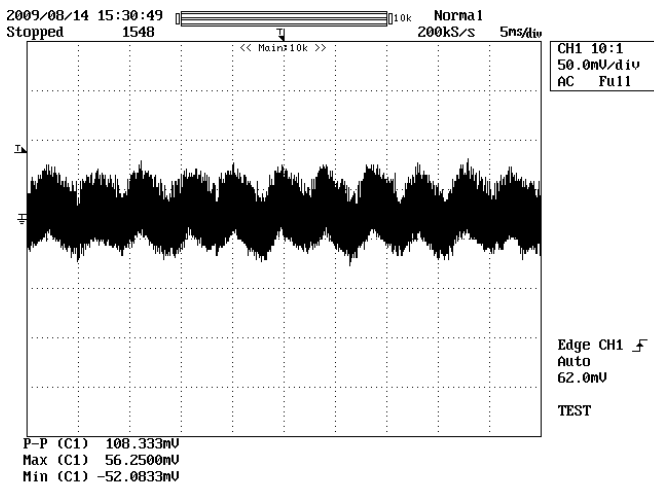


Figure 71 – Ripple, 115 VAC, Full Load.  
500 ms / div, 50 mV / div.

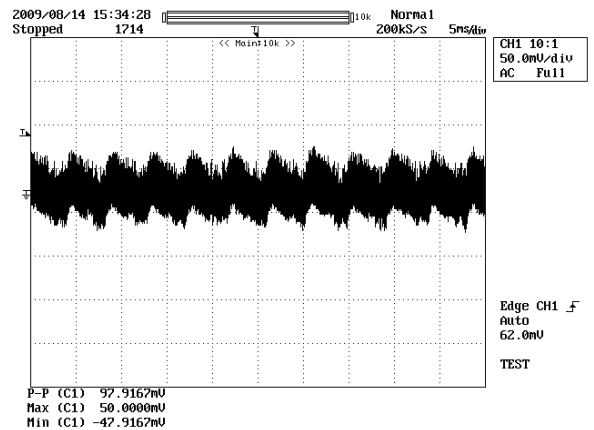
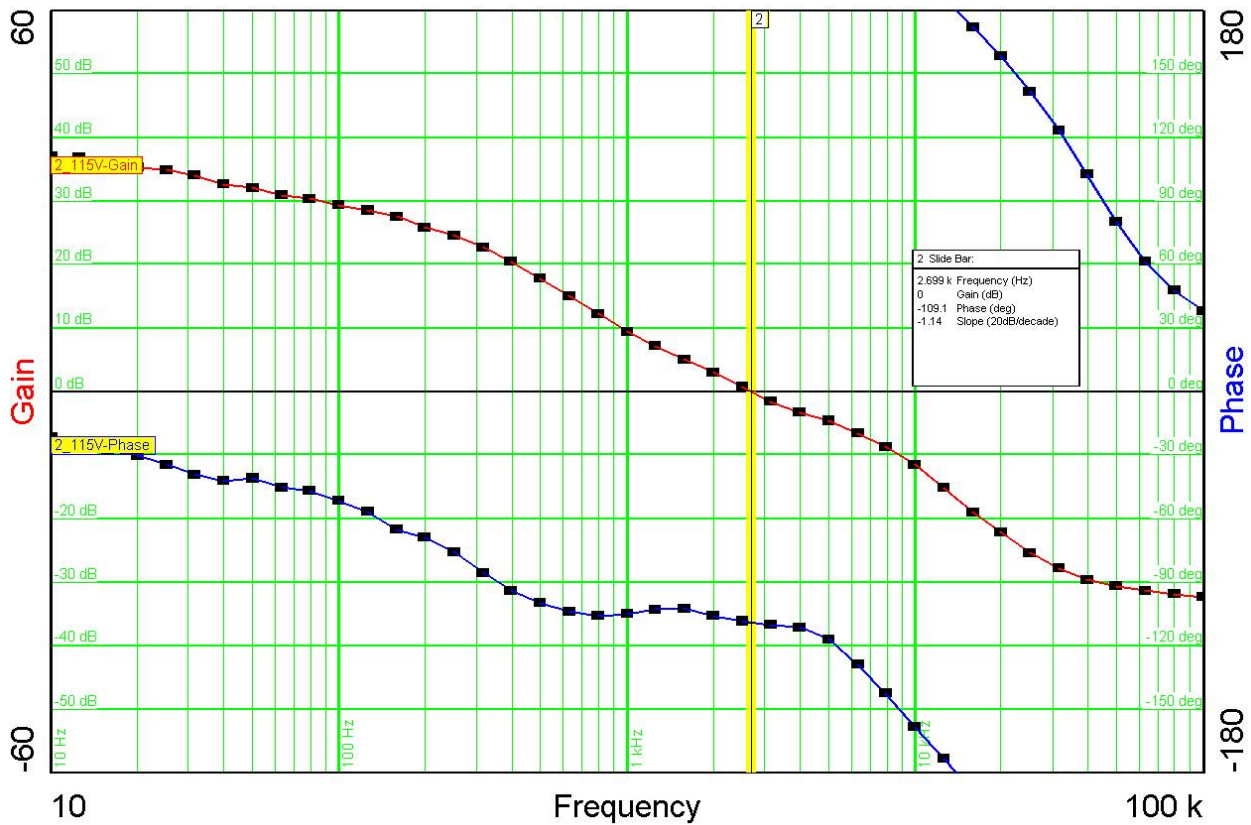


Figure 72 – Ripple, 265 VAC, Full Load.  
500 ms / div, 50 mV / div.

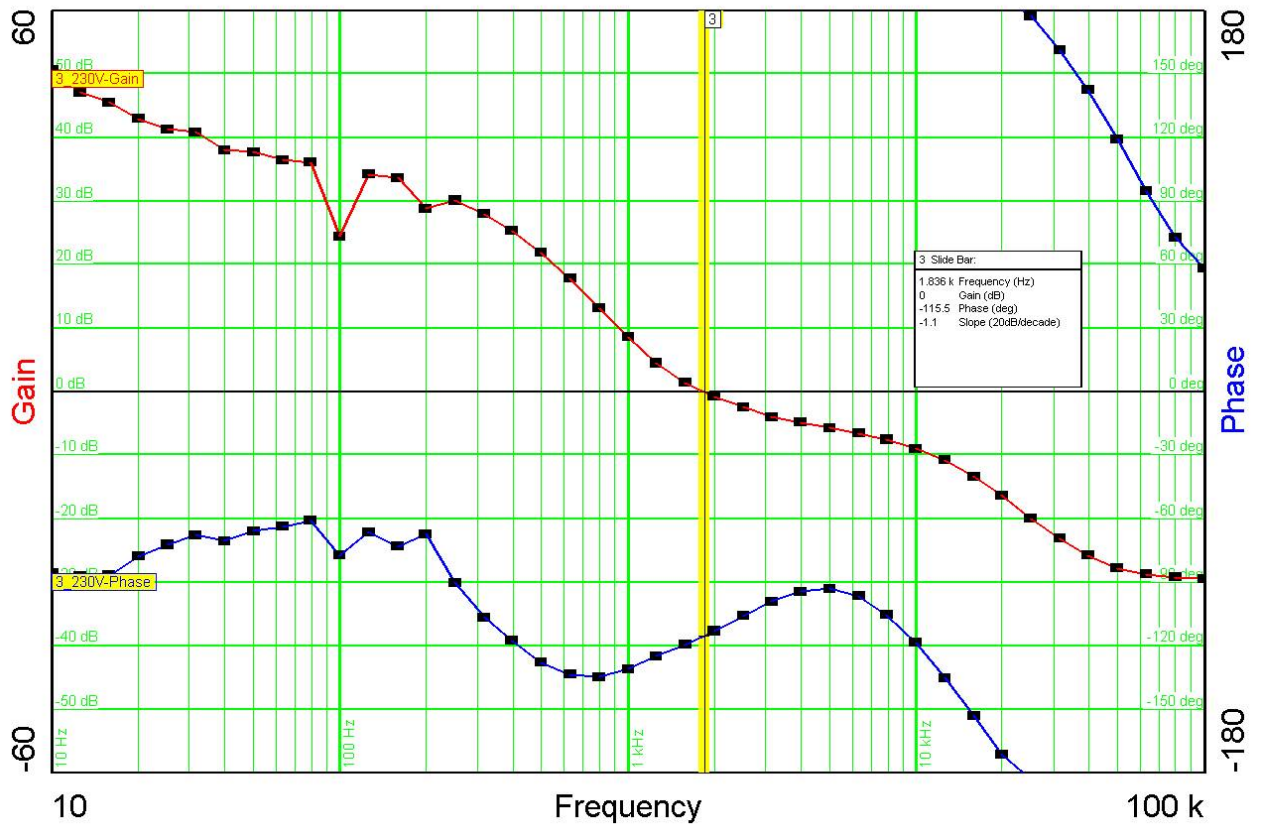


### 23 Control Loop Measurements

Venable System equipment was used to gather this data.



**Figure 73** – Gain-Phase Plot, 115 VAC, Maximum Steady State Load.  
 Vertical Scale: Gain = 20 dB / div, Phase = 30° / div.  
 Crossover Frequency = 2.699 kHz Phase Margin = 70.9°.



**Figure 74** – Gain-Phase Plot, 230 VAC, Maximum Steady State Load.  
 Vertical Scale: Gain = 20 dB / div, Phase = 50° / div.  
 Crossover Frequency = 1.836 Hz, Phase Margin = 64.5°.





## 24 Conducted EMI

Equipment used: Rohde and Schwarz ESPI3 (PN: m1142.8007.03 / EMI Test Receiver 9 kHz to 3 GHz).

The unit left running at least 15minutes to warm before the measurement were taken.

$$V_{OUT} = 19.5 \text{ V}$$

$$R_{LOAD} = 6 \Omega$$

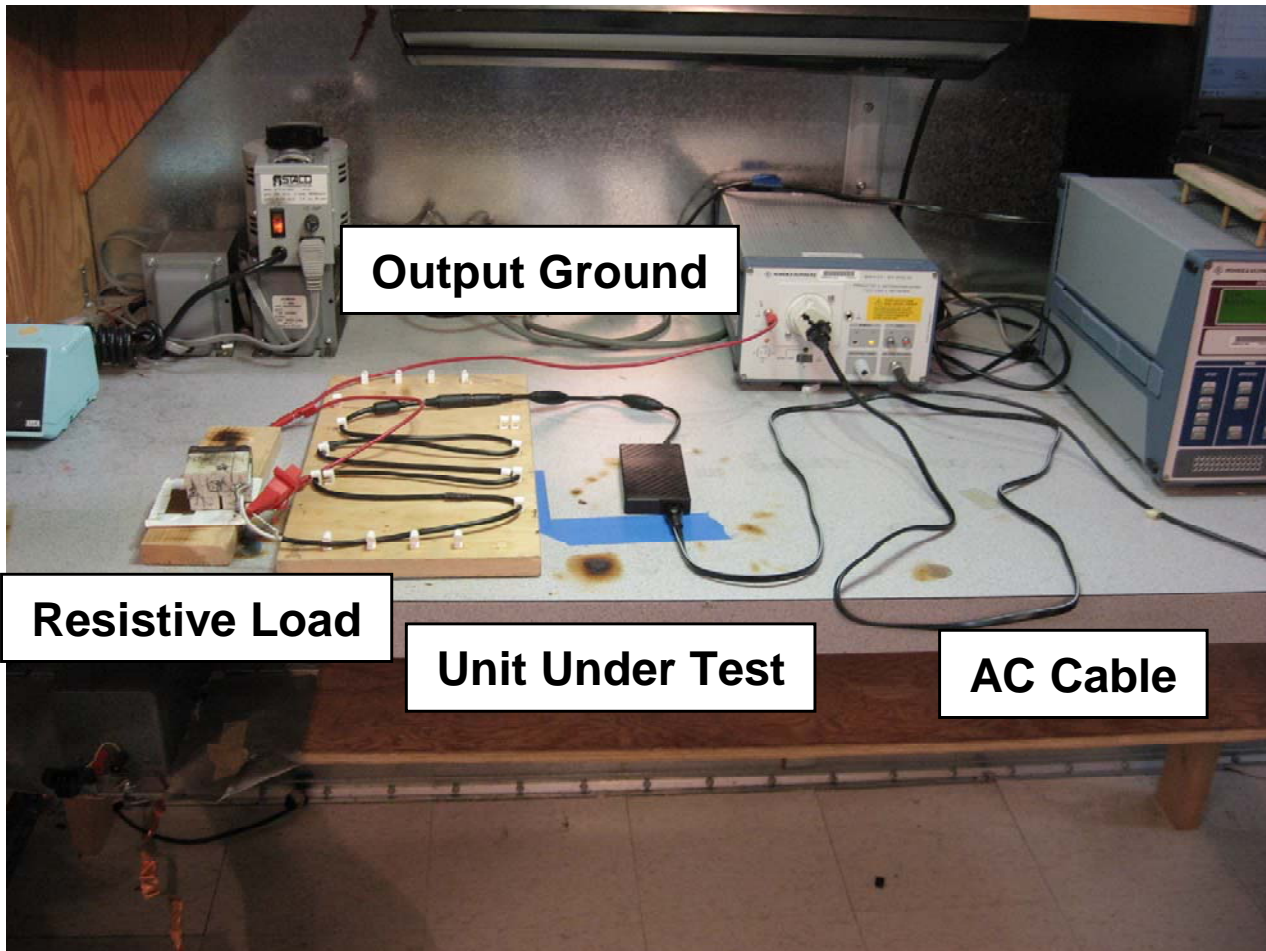


Figure 75 – Conducted EMI Set-Up.



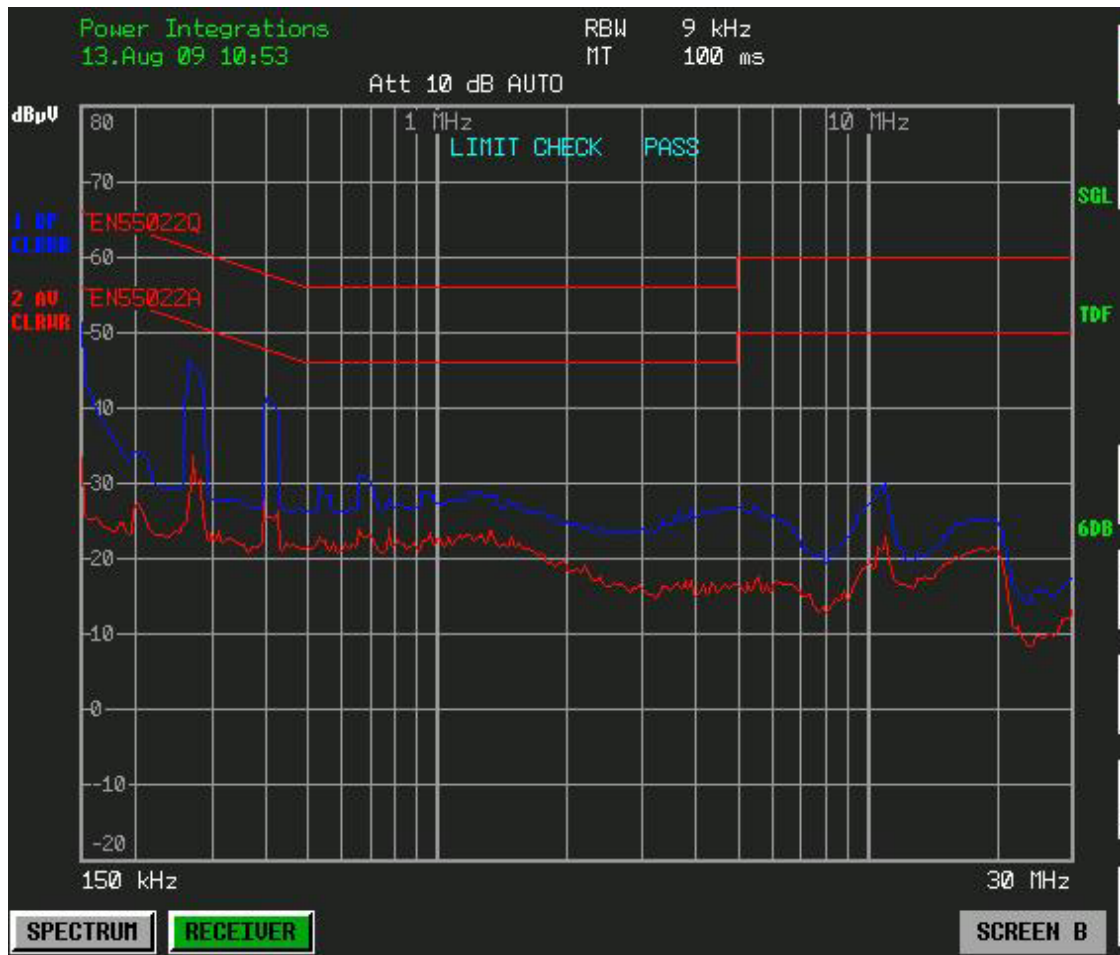


Figure 76 – Conducted EMI with 115 VAC Input, 6 Ω Resistive Load, Output floating.

Att 10 dB AUTO

EDIT PEAK LIST (Final Measurement Results)

Trace1: EN55022Q  
Trace2: EN55022A  
Trace3: ---

TRACE	FREQUENCY	LEVEL dBμV	DELTA LIMIT dB
1 Quasi Peak	150 kHz	50.83 N gnd	-15.16
1 Quasi Peak	266.376703545 kHz	48.73 L1 gnd	-12.50
2 Average	271.704237616 kHz	35.46 L1 gnd	-15.60
1 Quasi Peak	395.821768981 kHz	43.37 L1 gnd	-14.57
2 Average	403.738204361 kHz	29.99 L1 gnd	-17.78





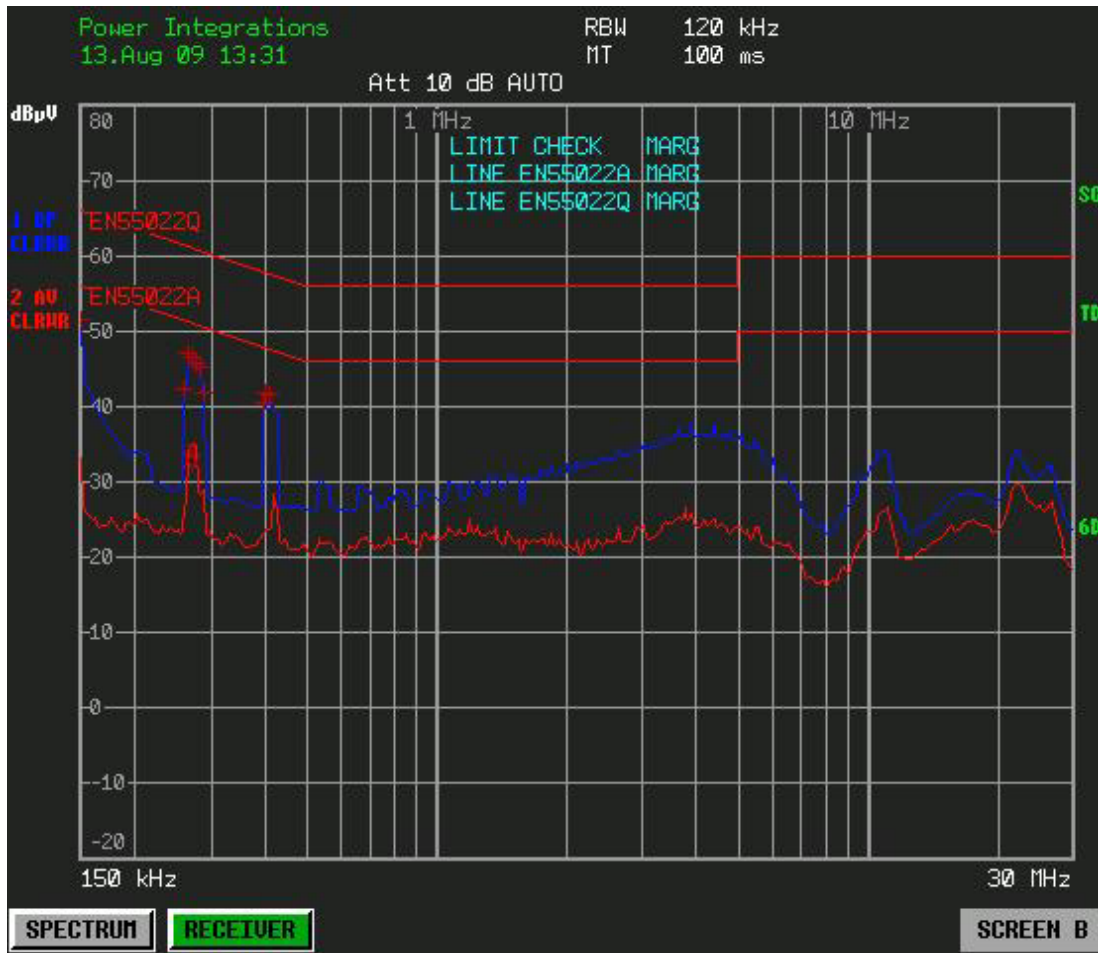


Figure 77 – Conducted EMI with 115 VAC Input, 6 Ω Resistive Load, Output Return Connected to PE.

Att 10 dB AUTO

EDIT PEAK LIST (Final Measurement Results)

TRACE	FREQUENCY	LEVEL dBµV	DELTA LIMIT dB
Trace1:	EN55022Q		
Trace2:	EN55022A		
Trace3:	---		
1 Quasi Peak	150 kHz	51.41 N gnd	-14.58
1 Quasi Peak	261.153630926 kHz	42.31 L1 gnd	-19.08
1 Quasi Peak	266.376703545 kHz	47.02 L1 gnd	-14.21
2 Average	266.376703545 kHz	32.90 L1 gnd	-18.32
1 Quasi Peak	271.704237616 kHz	46.48 L1 gnd	-14.58
2 Average	271.704237616 kHz	33.81 L1 gnd	-17.24
1 Quasi Peak	277.138322368 kHz	45.81 L1 gnd	-15.08
2 Average	277.138322368 kHz	32.61 L1 gnd	-18.28
1 Quasi Peak	282.681088815 kHz	45.09 L1 gnd	-15.64
1 Quasi Peak	288.334710591 kHz	41.81 L1 gnd	-18.75
1 Quasi Peak	395.821768981 kHz	40.60 L1 gnd	-17.33
1 Quasi Peak	403.738204361 kHz	41.80 L1 gnd	-15.96
1 Quasi Peak	411.812968448 kHz	41.57 L1 gnd	-16.03



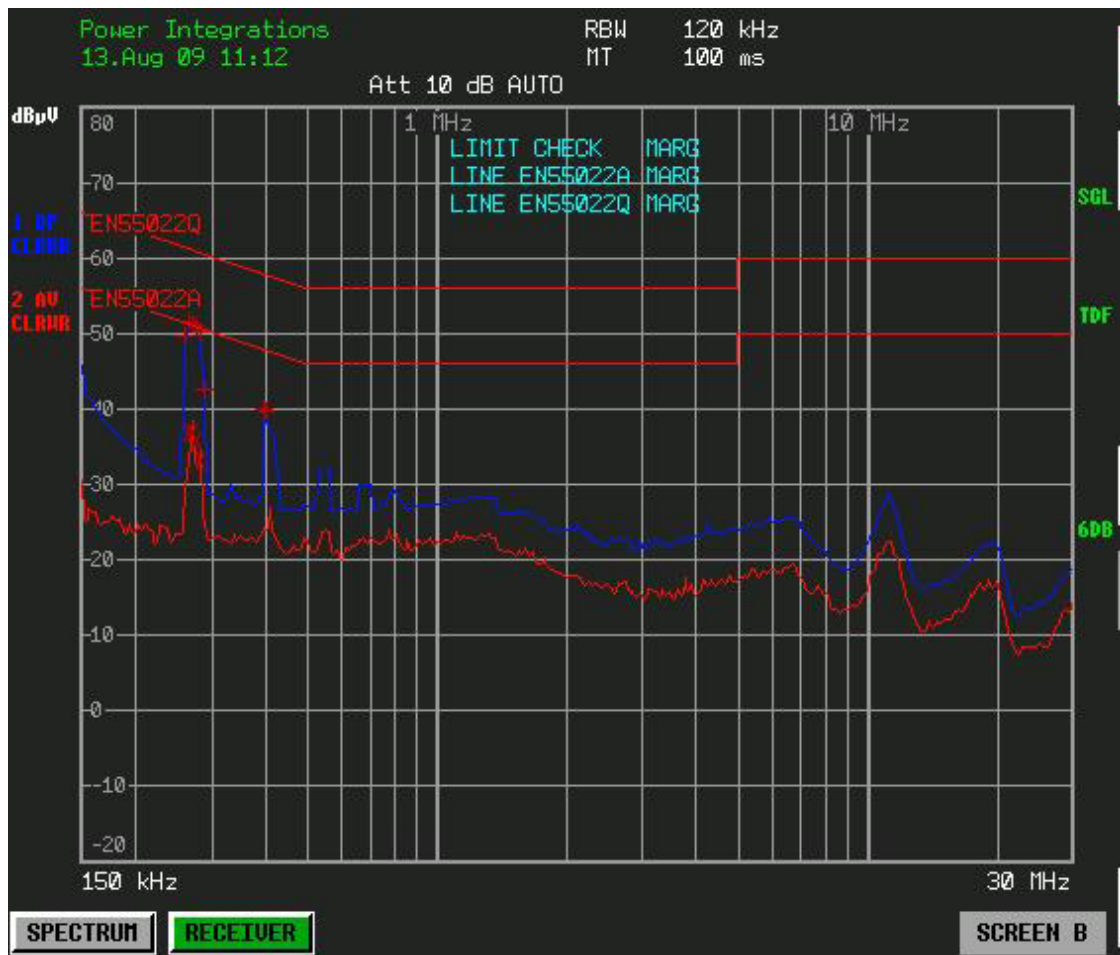


Figure 78 – Conducted EMI with 230 VAC Input, 6 Ω Resistive Load, Output Return Not-Connected to PE.

Att 10 dB AUTO

EDIT PEAK LIST (Final Measurement Results)

Trace1: EN55022Q  
Trace2: EN55022A  
Trace3: ---

TRACE	FREQUENCY	LEVEL dBμV	DELTA LIMIT dB
1 Quasi Peak	261.153630926 kHz	49.65 L1 gnd	-11.73
1 Quasi Peak	266.376703545 kHz	51.63 L1 gnd	-9.59
2 Average	266.376703545 kHz	36.80 L1 gnd	-14.42
1 Quasi Peak	271.704237616 kHz	51.38 L1 gnd	-9.68
2 Average	271.704237616 kHz	36.81 L1 gnd	-14.24
1 Quasi Peak	277.138322368 kHz	50.91 L1 gnd	-9.98
2 Average	277.138322368 kHz	35.82 L1 gnd	-15.08
1 Quasi Peak	282.681088815 kHz	50.29 L1 gnd	-10.44
2 Average	282.681088815 kHz	33.25 L1 gnd	-17.48
1 Quasi Peak	288.334710591 kHz	42.47 L1 gnd	-18.09
1 Quasi Peak	395.821768981 kHz	40.05 L1 gnd	-17.88
1 Quasi Peak	403.738204361 kHz	39.62 L1 gnd	-18.14



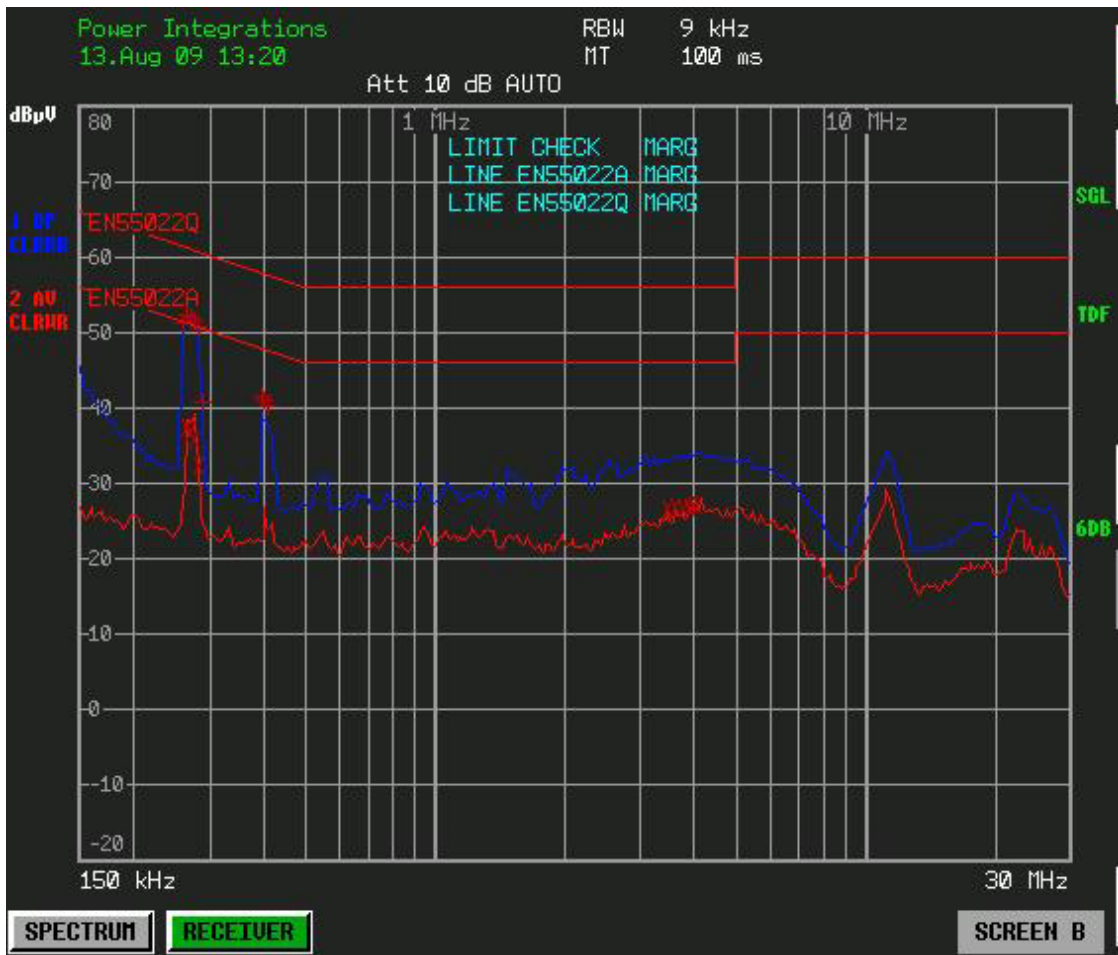


Figure 79 – Conducted EMI with 230 VAC Input, 6 Ω Resistive Load, Output Return Connected to PE.



Att 10 dB AUTO

EDIT PEAK LIST (Final Measurement Results)

Trace1: EN55022Q  
 Trace2: EN55022A  
 Trace3: ---

TRACE	FREQUENCY	LEVEL dBµV	DELTA LIMIT dB
1 Quasi Peak	261.153630926 kHz	51.17 L1 gnd	-10.22
1 Quasi Peak	266.376703545 kHz	52.39 L1 gnd	-8.83
2 Average	266.376703545 kHz	37.40 L1 gnd	-13.82
1 Quasi Peak	271.704237616 kHz	52.00 L1 gnd	-9.06
2 Average	271.704237616 kHz	36.90 L1 gnd	-14.16
1 Quasi Peak	277.138322368 kHz	51.55 L1 gnd	-9.34
2 Average	277.138322368 kHz	35.87 L1 gnd	-15.02
1 Quasi Peak	282.681088815 kHz	50.65 L1 gnd	-10.07
2 Average	282.681088815 kHz	32.43 N gnd	-18.30
1 Quasi Peak	288.334710591 kHz	40.87 L1 gnd	-19.70
1 Quasi Peak	395.821768981 kHz	41.59 L1 gnd	-16.34
1 Quasi Peak	403.738204361 kHz	41.03 L1 gnd	-16.73
1 Quasi Peak	411.812968448 kHz	40.30 L1 gnd	-17.31
2 Average	3.49557455365 MHz	26.52 L1 gnd	-19.47
2 Average	3.63679576561 MHz	26.96 L1 gnd	-19.03
2 Average	3.78372231454 MHz	26.70 L1 gnd	-19.29
2 Average	3.93658469605 MHz	26.83 L1 gnd	-19.17
2 Average	4.01531638997 MHz	27.06 L1 gnd	-18.93
2 Average	4.09562271777 MHz	27.14 L1 gnd	-18.85



## 25 Revision History

Date	Author	Rev.	Description	Reviewed
09-Feb-10	JG	1.0	Initial Release	Apps and Mktg



---

**For the latest updates, visit our website: [www.powerint.com](http://www.powerint.com)**

Power Integrations reserves the right to make changes to its products at any time to improve reliability or manufacturability. Power Integrations does not assume any liability arising from the use of any device or circuit described herein. POWER INTEGRATIONS MAKES NO WARRANTY HEREIN AND SPECIFICALLY DISCLAIMS ALL WARRANTIES INCLUDING, WITHOUT LIMITATION, THE IMPLIED WARRANTIES OF MERCHANTABILITY, FITNESS FOR A PARTICULAR PURPOSE, AND NON-INFRINGEMENT OF THIRD PARTY RIGHTS.

**PATENT INFORMATION**

The products and applications illustrated herein (including transformer construction and circuits external to the products) may be covered by one or more U.S. and foreign patents, or potentially by pending U.S. and foreign patent applications assigned to Power Integrations. A complete list of Power Integrations' patents may be found at [www.powerint.com](http://www.powerint.com). Power Integrations grants its customers a license under certain patent rights as set forth at <http://www.powerint.com/ip.htm>.

The PI Logo, TOPSwitch, TinySwitch, LinkSwitch, DPA-Switch, PeakSwitch, EcoSmart, Clampless, E-Shield, Filterfuse, StackFET, PI Expert and PI FACTS are trademarks of Power Integrations, Inc. Other trademarks are property of their respective companies. ©Copyright 2010 Power Integrations, Inc.

---

## Power Integrations Worldwide Sales Support Locations

**WORLD HEADQUARTERS**

5245 Hellyer Avenue  
San Jose, CA 95138, USA.  
Main: +1-408-414-9200  
Customer Service:  
Phone: +1-408-414-9665  
Fax: +1-408-414-9765  
*e-mail:*  
[usasales@powerint.com](mailto:usasales@powerint.com)

**GERMANY**

Rueckertstrasse 3  
D-80336, Munich  
Germany  
Phone: +49-89-5527-3911  
Fax: +49-89-5527-3920  
*e-mail:*  
[eurossales@powerint.com](mailto:eurossales@powerint.com)

**JAPAN**

Kosei Dai-3 Building  
2-12-11, Shin-Yokohama,  
Kohoku-ku, Yokohama-shi,  
Kanagawa 222-0033  
Japan  
Phone: +81-45-471-1021  
Fax: +81-45-471-3717  
*e-mail:* [japansales@powerint.com](mailto:japansales@powerint.com)

**TAIWAN**

5F, No. 318, Nei Hu Rd., Sec. 1  
Nei Hu District  
Taipei 114, Taiwan R.O.C.  
Phone: +886-2-2659-4570  
Fax: +886-2-2659-4550  
*e-mail:*  
[taiwansales@powerint.com](mailto:taiwansales@powerint.com)

**CHINA (SHANGHAI)**

Rm 1601/1610, Tower 1  
Kerry Everbright City  
No. 218 Tianmu Road West  
Shanghai, P.R.C. 200070  
Phone: +86-021-6354-6323  
Fax: +86-021-6354-6325  
*e-mail:*  
[chinasales@powerint.com](mailto:chinasales@powerint.com)

**INDIA**

#1, 14<sup>th</sup> Main Road  
Vasanthanagar  
Bangalore-560052  
India  
Phone: +91-80-4113-8020  
Fax: +91-80-4113-8023  
*e-mail:*  
[indiasales@powerint.com](mailto:indiasales@powerint.com)

**KOREA**

RM 602, 6FL  
Korea City Air Terminal B/D, 159-6  
Samsung-Dong, Kangnam-Gu,  
Seoul, 135-728  
Korea  
Phone: +82-2-2016-6610  
Fax: +82-2-2016-6630  
*e-mail:* [koreasales@powerint.com](mailto:koreasales@powerint.com)

**UNITED KINGDOM**

1st Floor, St. James's House  
East Street,  
Farnham Surrey, GU9 7TJ  
United Kingdom  
Phone: +44 (0) 1252-730-141  
Fax: +44 (0) 1252-727-689  
*e-mail:*  
[eurossales@powerint.com](mailto:eurossales@powerint.com)

**CHINA (SHENZHEN)**

Rm A, B & C 4<sup>th</sup> Floor, Block C,  
Electronics Science and  
Technology Building  
2070 Shennan Zhong Road  
Shenzhen, Guangdong,  
P.R.C. 518031  
Phone: +86-755-8379-3243  
Fax: +86-755-8379-5828  
*e-mail:*  
[chinasales@powerint.com](mailto:chinasales@powerint.com)

**ITALY**

Via De Amicis 2  
20091 Bresso MI  
Italy  
Phone: +39-028-928-6000  
Fax: +39-028-928-6009  
*e-mail:*  
[eurossales@powerint.com](mailto:eurossales@powerint.com)

**SINGAPORE**

51 Newton Road,  
#15-08/10 Goldhill Plaza  
Singapore, 308900  
Phone: +65-6358-2160  
Fax: +65-6358-2015  
*e-mail:*  
[singaporesales@powerint.com](mailto:singaporesales@powerint.com)

**APPLICATIONS HOTLINE**

World Wide +1-408-414-9660

**APPLICATIONS FAX**

World Wide +1-408-414-9760

